



## 2024 Ginetta GT Academy

### Sporting, Technical and Commercial Regulations and Registration Document



motor  
sport  
UK



---

A Motorsport UK recognised motor racing championship, registered by:

**British Racing and Sports Car Club**

**PUBLISHED**

26 March 2024

## **CONTENTS**

<b>1. SPORTING REGULATIONS – GENERAL</b>	<b>3</b>
<b>2. SPORTING REGULATIONS – JUDICIAL PRODEDURES</b>	<b>10</b>
<b>3. SPORTING REGULATIONS – CHAMPIONSHIP RACE MEETING &amp; RACE PROCEDURES</b>	<b>11</b>
<b>4. CHAMPIONSHIP RACE PENALTIES</b>	<b>23</b>
<b>5. TECHNICAL REGULATIONS – GENERAL</b>	<b>25</b>
<b>6. TECHNICAL REGULATIONS – GINETTA GTA</b>	<b>28</b>
<b>7. ROOKIE CLASS ADDITIONAL REGULATIONS</b>	<b>43</b>
<b>8. COMMERCIAL REGULATIONS</b>	<b>44</b>
<b>9. 2024 SUPPORT SERIES ENVIRONMENTAL GUIDELINES 2024 CIRCUIT GREEN CHARTER GUIDELINES</b>	<b>53</b>
<b>10. CHAMPIONSHIP CONTACTS</b>	<b>55</b>

## **APPENDICIES**

<b>A. GT ACADEMY DECAL LAYOUT</b>	<b>56</b>
<b>B. RACE SUITS LOGO PLACEMENT</b>	<b>56</b>
<b>C. MSUK RACE WITH RESPECT</b>	<b>57</b>

# 1. SPORTING REGULATIONS – GENERAL

## 1.1 TITLE & JURISDICTION

1.1.1 The 2024 GINETTA GT ACADEMY is organised and administered by the British Racing and Sports Car Club (BRSCC) on behalf of Commercial Rights Holder Ginetta Cars Ltd in accordance with the General Regulations of Motorsport UK (incorporating the provisions of the International Sporting Code of the FIA) and these Championship Regulations. The Organisers reserve the right to issue additional statements clarifying items in the rules and regulations and all such statements will be issued to all registered drivers by posting to the address details or email details on the Registration form.

The Championship Permit is granted by the ASN to and held by BRSCC. The Championship Events are organised by BRSCC and the Championship is promoted and administered by Ginetta Cars Ltd. The Championship is organised pursuant to the General Regulations of Motorsport UK (incorporating the provisions of the International Sporting Code of the FIA) (the "Motorsport UK Regulations") and these Championship Regulations.

For the purposes of these Championship Regulations BRSCC and Ginetta Cars Ltd shall be jointly and severally referred to as the Organisers, however for the avoidance of doubt BRSCC shall be accountable to the ASN as the Championship Permit Holder.

- 1.1.2 Motorsport UK Championship Permit No: CH2024/R053
- 1.1.3 Race Status: Inter Club
- 1.1.4 Motorsport UK Championship Grade: C

## 1.2 OFFICIALS

- 1.2.1 Championship Coordinator: Kelly Edmund Ginetta Cars Ltd
- 1.2.2 Licence Eligibility Scrutineer: Ron Humphreys
- 1.2.3 Deputy Licence Eligibility Scrutineer: Clive Greves
- 1.2.4 Championship Stewards: Greg Masters BRSCC  
Trevor Parry BRSCC  
David Simons BRSCC  
Esmor Jones BRSCC
- Any three of the above may reach a decision
- 1.2.6 Championship Clerk of the Course Paul Levitt BRSCC

## 1.3 COMPETITOR ELIGIBILITY

- 1.3.1 Entrants must
- be fully paid up valid membership card holding members of BRSCC and
  - be Registered for the Championship and
  - be in possession of a valid Motorsport UK Entrants Licences

### 1.3.2 Drivers must

- be current Members of BRSCC and
- be Registered for the Championship and
- be in possession of valid Competition (Racing) Interclub\* status Licence, *as a minimum*
- \*Or be in possession of the highest grade of national Race licence or valid FIA International Licence, together with their ASN's written consent ((H)26.2. and FIA ISC Article 2.3.7.b applies)
- \*If participation in the Championship requires absence from education a driver, in full time school education is required to have the approval of their head teacher and a letter stating such approval from their school in order to fulfil registration for the Championship. A driver shall not take time out of their education to participate in motor sport without the prior written approval of their education establishment.

1.3.3 All necessary documentation must be presented to the Organisers for checking at all rounds when signing-on.

1.3.4 Only those cars complying with the 2024 Technical Regulations for the Championship and any amendments to the Technical Regulations issued from time to time by way of an official Championship Bulletin in accordance with Motorsport UK Regulation D11.2. will be allowed to compete in any round of the Championship.

1.3.5 Where there is a Team that is responsible for preparation of a Competitor's vehicle but that Team is not an Entrant as provided by the Motorsport UK General Regulations nonetheless such Team shall be accountable to the Organisers under these Regulations as though it were an Entrant but relation to the Driver. Under the Ginetta Franchise agreement, all teams must hold a valid Entrants Licence.

1.3.6 Entrants/Drivers must ensure that their cars comply with the conditions of eligibility and safety throughout qualifying and racing. At any time during an Event the Championship Clerk of the Course can require a Driver to have a medical examination by the Medical Adviser or his/her nominee.

1.3.7 The 2024 GINETTA GT ACADEMY will have two categories within the Championship: GT Academy Class, and Rookie Class. Competitors will be able to place themselves in the appropriate category to reflect their driving ability. Competitors must indicate on their Registration Form which category they would place themselves. The Ginetta GT Academy Organisation will review the applications and decide whether to accept it.

1.3.8 Rookie class competitors must comply with all of **Section 7** of these regulations to be eligible to compete in this class.

1.3.9 The Championship organisation reserves the right to amend a chosen drivers' category at any time.

1.3.10 Drivers who enter the GT Academy category cannot move to the Rookie category after round 2 of the Championship.

1.3.11 Any change to a Driver's Category will not affect the Championship Points earned by that Driver prior to the Category change. For the avoidance of doubt, Category Points cannot be transferred from one Category to another. If a Driver changes from one Class to the other Class during the season, their points for the new Class will start from Zero.

## **1.4 REGISTRATION**

- 1.4.1 All Entrants and / or Teams and all drivers must register for the Championship by returning the Applicable Registration Form(s) in full to the Coordinator prior 31<sup>st</sup> January 2024. Registrations are accepted on a “first come first served basis” but always subject to Arts. **1.4.7, 1.4.8, 1.4.11** of these Championship Regulations. The Organisers reserve the right to accept Registrations after this date. Acceptance of Registration and the terms thereof is at the discretion of the Organisers.
- 1.4.2 The Drivers Registration Form must be completed in full and be signed by the driver and if applicable by the Entrant / Team and be accompanied by the Driver’s Registration Fee in full in order to be considered. If applicable the Registration Form must also be counter signed by the Parents or Legal Guardian of the driver in all cases where the driver is under the age of 18 years at the date of Registration. Signature by Entrant and / or Team must be by an officer in the case of a limited liability company regardless of its jurisdiction and by a principal in the case of a partnership or sole trader.
- 1.4.3 The acceptance or rejection of a Registration application will be based upon the information given on the Registration Form. It is therefore a condition of Registration that drivers accept that the BRSCC reserves the right to reject Registration applications and / or entries to individual events without giving reasons in accordance with current Motorsport UK GR.
- 1.4.4 The Drivers Registration and Entry Fee combined is:
- £17,100. plus VAT per driver.
- 1.4.5 Cheques should be made payable to Ginetta Cars Ltd. This Registration fee is fully inclusive of entry fees to all rounds of the Championship timing fees and medical provision. This fee is payable in full by all Ginetta franchised team prior to the 31<sup>st</sup> January 2024. Entry fees may not be paid by account.
- 1.4.6 The Drivers Registration Fee is not inclusive of BRSCC membership.
- 1.4.7 A Registration once made and accepted shall constitute a legally binding contract and a Registration may only be withdrawn without penalty with the mutual consent of both parties. An Entrant or driver whose Registration is accepted and who otherwise fails to participate in the Championship shall forfeit their Registration fees in their entirety.
- 1.4.8 The Organisers may accept or refuse any entry or Registration and withdraw or revoke a Registration at any time should the continued Registration of the competitor or team be deemed by the Organisers in their absolute discretion not to be in the best interests of the Championship or of the Commercial Regulations.
- 1.4.9 Registrations will be accepted from 1<sup>st</sup> December 2023 until further notice. A maximum of 38 Registrations will be accepted for entry into the Championship on a first come first served basis. Any Registrations received after the first 38 may be held as entry reserves for the Championship at the discretion of The Organisers.
- 1.4.10 Registration numbers will be the permanent Competition numbers for the Championship and will be allocated by the Coordinator. Numbers 1 through 3 are reserved for Championship Organisers use and will be allocated to returning drivers.
- 1.4.11 All Entrants and Teams Registration fee is included in the entry fee.

- 1.4.12 For the purposes of these Championship Regulations all Registrants must notify the Organisers in writing of any change of address and / or e mail address that occurs during the term of the Championship.
- 1.4.13 Competitors not registered for the Championship may be permitted on an individual round basis and will;
- Be deemed “Guest Competitors”
  - Not score points and for the purpose of points scoring will be ignored
  - Qualify for Event awards
- 1.4.14 Guest Competitors may be permitted to make guest appearances at the sole discretion of the Organisers and subject to such conditions as they may stipulate from time to time but subject to meeting the licence requirements of these Sporting Regulations. As a condition of Registration and entry no guest driver is able to score points or be awarded prize money in the Championship. Drivers must be members of the BRSCC in accordance with 1.3.2. The Registration form must be completed but the payment of the driver’s Registration fee specified in these Regulations is waived and a fee of £50.00 will apply. Otherwise all regulations of the Championship must be observed.

## 1.5 CHAMPIONSHIP ROUNDS

- 1.5.1 The 2024 GINETTA GT ACADEMY be contested over 7 EVENTS as follows:

ROUNDS	VENUE	DATES
1,2,3	Oulton Park SRO	30 March/01 April
4,5	Silverstone <i>GP</i> SRO	27/28 April
6,7,8	Donington Park <i>GP</i> SRO	25/26 May
9,10,11,12	Anglesey <i>International</i> <i>GINETTA FESTIVAL</i>	29/30 June
13,14,15	Snetterton <i>300</i> SRO	13/14 July
16,17,18	Donington Park <i>GP</i> SRO	07/08 September
19,20,21	Brands Hatch <i>GP</i> SRO	28/29 September

- 1.5.2 In accordance with Motorsport UK regulation D11.2 the organisers reserve the right to amend the published list of dates and rounds in which case all registered competitors will be informed of the amendments by Official Bulletins emailed to the email address specified on the Official Registration Form (note Art. **1.4.1** of these Championship Regulations). Motorsport UK Regulations Q7.11 applies.
- 1.5.3 The Championship will feature official pre-event and Ginetta Exclusive Test Days. All official test dates will be confirmed via an Official Ginetta Cars Bulletin in due course.

## 1.6 CHAMPIONSHIP ROUNDS

1.6.1 The Ginetta GT Academy has a class structure, and points will be awarded separately for each of the classes:

- GTA
- Rookie

1.6.2 Points will be awarded to GT Academy and Rookie competitors listed as classified finishers in the final results as follows: **35, 30, 26, 22, 20, 18, 16, 14, 12, 11, 10, 9, 8, 7, 6, 5, 4, 3, 2, 1** plus **1** for fastest race lap in each race.

If a race is suspended/abandoned and cannot be resumed or rescheduled at another event, the following points will be applied.

- No points will be awarded to the drivers or teams if the leader has completed less than two laps:
- The following points will be awarded to the drivers and teams if the leader has completed two or more than two laps but less than 75% of the original race time:
- Points will be awarded to Competitors listed as classified finishers in the Final Results as follows:

**20, 18, 16, 14, 12, 11, 10, 9, 8, 7, 6, 5, 4, 3, 2, 1** plus **1** for the fastest lap in qualifying and **1** for fastest race lap in each race.

Full points will be awarded if the leader has completed more than 75% of the original race time.

The above will be based on the final classification and results published on this basis.

1.6.3 One additional point will be awarded to the driver who starts on Pole Position for the First Race of each event in each class.

1.6.4 The total combined scores from the FIVE highest points scoring EVENTS will determine the final Championship points and positions. An event is the total of any races held over a race weekend, if that be the full accompaniment of races or not.

1.6.5 Competitors will NOT be able to drop an event set of points if one of the following occurrences has arisen at any point during that event:

- The competitor has been penalised with points on his/her Motorsport UK licence for any incident.
- The competitor has been given a points penalty / reduction for any incident
- The competitor is disqualified from a classified race result

1.6.6 Ties shall be resolved using the formula in Regulation W1.3.4 of the current Motorsport UK General Regulations.

## 1.7 AWARDS – ROUNDS

1.7.1 All awards are to be provided by Ginetta Cars Ltd.

- Trophies per Championship Round: 1<sup>st</sup>, 2<sup>nd</sup> & 3<sup>rd</sup> in each class.

- Chairman's Cup Awards – a trophy presented to the top three placed drivers over the age of 45 (or turning 45 during the current calendar year), regardless of class.

1.7.2 Any Guest Competitor entered on behalf of Ginetta Cars Ltd will qualify for Championship round trophies.

## **1.8 AWARDS – CHAMPIONSHIP**

Trophies:

Championship: 1<sup>st</sup>, 2<sup>nd</sup> & 3<sup>rd</sup>.

Championship Prizes:

### **GT Academy Class**

1<sup>st</sup> Free entry and use of Ginetta G56 GT Pro car for the 2025 Protyre Motorsport Ginetta GT Championship.

2<sup>nd</sup> Free entry for 2025 Ginetta Championship of choice.

3<sup>rd</sup> Half price entry for 2025 Ginetta Championship of choice.

### **Rookie Class**

1<sup>st</sup> Half price entry for 2025 Ginetta Championship of choice.

1.8.1 Other additional Championship awards – In the event of additional Championship awards being introduced all Registered competitors will be informed by official bulletin.

1.8.2 Championship awards will be presented at the annual awards dinner hosted by Ginetta Cars, which is a mandatory requirement for top Three Drivers from each class to attend. An additional Championship Trophy will be presented by the BRSCC at its Annual Championship Prize Dinner (Date and venue to be announced by BRSCC). Any such recipient failing to attend these events may not be eligible to receive any prizes which may otherwise have been presented. Such prizes may be with-held and may not be re-presented to any other person.

1.8.3 Ginetta Parts Credit may be exchanged for parts only as supplied by Ginetta Cars. For the avoidance of doubt Parts Credit cannot be used against entry fees labour costs lease costs or vehicle acquisition payments. Parts Credit must be redeemed within a 12-month period of being issued to the driver.

1.8.4 Parts Credit must be used by the driver it has been issued to and is non-transferable. All free entry prizes are for the driver in receipt of the prize and are non-transferable.

1.8.5 In the event of the average grid size in each class being less than 10 cars over the course of the season all prizes may be reduced in value by 50%.

## **1.9 ENTERTAINMENT TAX LIABILITY**

1.9.1 Entertainment Tax Liability: In accordance with current government legislation Ginetta Cars Ltd is legally obliged to withhold tax at the basic rate on all payments to non-UK resident sportsmen/women. That is those persons who do not have a normal permanent residence in the UK. The UK does not include the Isle of Man Channel Islands or Eire. This means that as the organiser Ginetta Cars Ltd is required to deduct tax at the relevant rate from any such payments they may make to non-UK residents.



- 1.9.2 Under certain circumstances it may be possible for competitors to enter into an agreement with the Inland Revenue to limit the tax withheld. Any application must be made in writing and not later than 30 days before the payment is due. For further information contact:
- 1.9.3 The Inland Revenue Foreign Entertainers Unit Centre for Non-Residents St John's House Merton Road Merseyside L69 9BB. Tel: 0151 472 6488. Fax: 0151 472 6483).

#### **1.10 MOTORSPORT UK'S RESPECT CODE**

- 1.10.1 By registering for the Championship all competitors and their associates commit to positively promote and demonstrate the Motorsport UK's Respect Code which is appended to these regulations (Appendix C).
- 1.10.2 Where any reports of disrespectful conduct are judged to be well founded the Championship organisers may issue warnings or require remedial actions and/or report the matter to the Championship Stewards who may impose appropriate penalties which can include loss of Championship points and/or race bans through to Championship Expulsion and referral to Motorsport UK.
- 1.10.3 It is imperative that we promote the safety and wellbeing of young people and adults at risk. In addition to this all participants must be aware of their behaviour and conduct at all times and abusive language and harmful behaviour will not be tolerated. Any such incidents must be reported to the Championship Coordinator and/or Safeguarding Officer who will also relay the report Motorsport UK. Details of the Motorsport UK Policies and Guidelines are available at [www.motorsportuk.org/resource-centre](http://www.motorsportuk.org/resource-centre) by selecting Policies and Guidelines.

## **2. SPORTING REGULATIONS – JUDICIAL PROCEDURES**

### **2.1 ROUNDS**

- 2.1.1 In accordance with the current Motorsport UK General Regulations and these Regulations.

### **2.2 CHAMPIONSHIP**

- 2.2.1 In accordance with the current Motorsport UK General Regulations and these Regulations.
- 2.2.2 Driving Standards: Breaches of driving standards during practice or race will be dealt with firmly.
- 2.2.3 The Clerk of the Course may at their discretion wish to review any evidence in order to assist with his enquiry into an alleged breach of driving standards and accordingly he may order that the results remain provisional and may take judicial action at a later date.
- 2.2.4 The Championship Coordinator pursuant to Motorsport UK General regulation W.2.2.1 and these Championship Regulations and in any event may in his / her absolute discretion refer any Registered Competitor Entrant or Team and in respect of any dispute or irregularity arising howsoever under these Championship Regulations including all and any amendment of them to the Championship Stewards who after conducting a Hearing shall be empowered to impose any penalty permitted under Motorsport UK General Regulation C.2.1.1 and to revoke any Registration under these Championship Regulations.
- 2.2.5 The Championship Organisers may also within 14 days of the event and provided that the results have remained provisional be entitled to request the Championship Stewards to enquire into any driving standards or any conduct matter notwithstanding that the Clerk of the Course and/or the Stewards of the Meeting may or may not have already investigated the incident and / or referred the matter to Motorsport UK. The Championship Stewards will be empowered to take further action if they deem it necessary which could include disqualification from part or all of the Championship.

### **2.3 JUDICIAL HEARINGS**

- 2.3.1 If a competitor is involved in a collision or incident, they must not leave the circuit (except where medically evacuated) without the consent of the Clerk of the Course, failing which, any judicial action against or relating to that Entrant / Driver may be heard in their absence.
- 2.3.2 When attending a judicial hearing, all drivers may be accompanied by a maximum of ONE team representative or driver coach. Where the driver is under 18, this team representative/driver coach must be the signed-on guardian for the event, in place the drivers Parent/Legal Guardian.

### **3. SPORTING REGULATIONS - CHAMPIONSHIP RACE MEETINGS & RACE PROCEDURES**

#### **3.1 ENTRIES**

- 3.1.1 The Championship Registration Form that includes the race Entry Form can be found online at; <https://hub.ginetta.com/>
- 3.1.2 Entrants and / or Teams are responsible for sending in fully completed Registration Forms signed as required by these Championship Regulations together with the Registration fee to the Championship Coordinator prior to the closing date of 31<sup>st</sup> January 2024. The Organisers reserves the absolute right to accept Registration/entries after that date.
- 3.1.3 Any withdrawal of entry or amendments to an entry must be notified to the Championship Coordinator in writing by the Registrant. If changes are made after publication of Entry Lists with Final Instructions the Entrant/Driver concerned must apply for approval of acceptance by the Stewards of the Meeting before signing-on.
- 3.1.4 Entry for each round is included in the Registration Fee.
- 3.1.5 Qualification races will be held at the discretion of the Organisers.
- 3.1.6 Any reserves are to be nominated by the Organisers on the Final List of Entries published with Final Instructions or Amendment Sheet Bulletins. All reserves will practice and replace withdrawn or retired entries in Reserve Number order irrespective of class. If any Reserves are given Grid Places prior to issue of the first Grid Sheets for any round the times set in practice shall determine their grid positions. If Reserves are given Grid Places after publication of the Grid Sheet and prior to cars collecting in the Official "Assembly Areas" they will be placed at the rear of the Grid and will be started WITHOUT any time delay. Otherwise they will be held in the pit-lane and be released to start the race after the last car to start the GREEN FLAG LAP or last car to take the start has passed the start line or pit-lane exit whichever is the later. Such approval to start MUST be obtained from the designated Clerk of the Course.
- 3.1.7 All drivers and entrants agree to the terms listed in the Franchise agreement, regulation **8.5**.

#### **3.2 BRIEFINGS**

- 3.2.1 The Organisers will notify Competitors of the times and locations for all briefings in the Final Instructions for the events or by bulletin at the event. Competitors must attend all briefings.

#### **3.3 SCRUTINEERING PROTOCOL**

- 3.3.1 The Championship Organisers will appoint a permanent Licenced Eligibility Scrutineer who with his team will be responsible for the scrutineering of the vehicles for the qualifying sessions and races of the Championship in accordance with Regulation **1.5.1**.
- 3.3.2 For scrutineering the Entrant/Driver must present the competing vehicle and mandatory Entrant/Driver safety equipment. The vehicle must be submitted as used in the Championship and must correspond to all applicable Technical Regulations.
- 3.3.3 A completed component sealing forms for each vehicle must be correctly submitted via an online Ginetta form unless the Championship Licenced Eligibility Scrutineer requests otherwise. Details of submissions will be emailed out in pre-event bulletins.
- 3.3.4 Aside from the official safety scrutineering the vehicles may also be subject to eligibility scrutineering during and after the Event. Vehicles will be selected at the sole discretion of

the Licenced Eligibility Scrutineer and/or his nominated representative. The Licenced Eligibility Scrutineer and/or his nominated representative will make random checks in addition to scheduled scrutineering checks for vehicle eligibility throughout Events. Any infringement will be subject to a report to the Championship Clerk of the Course.

- 3.3.5 Entrants/Drivers must comply with the directives of the Licenced Eligibility Scrutineer and/or his nominated representative in respect of scrutineering and of re-scrutineering after the Event.
- 3.3.6 After each qualifying session and race the vehicles must be presented directly for scrutineering. Any area deemed necessary by the Licenced Eligibility Scrutineer and/or their nominated representative will be subject to Parc Fermé conditions with no exceptions. This will include the track from the Finish Line to the scrutineering area the waiting area in front as well as the track from the scrutineering area to Parc Fermé but all areas may be used if necessary.
- 3.3.7 Public and team personnel must not enter Parc Fermé unless invited by the Licenced Eligibility Scrutineer and/or his nominated representative. Should unauthorised team personnel be present in these areas they render their car liable to disqualification from the qualifying session or race. Any breach of Parc Fermé regulations will be reported to the Clerk of the Course who may impose penalties as appropriate. At their discretion the Clerk of the Course or Organisers may assign other penalties to any driver / team breaching Parc Fermé regulations. On request of the Licenced Eligibility Scrutineer the Parent or Legal Guardian of the driver will be permitted in Parc Fermé.
- 3.3.8 Cars may be held in Parc Fermé for a minimum of 20 (twenty) minutes after each qualifying session and race and in any event shall so remain in Parc Fermé condition until released by the Licenced Eligibility Scrutineer.
- 3.3.9 At any time, the Championship Organisers reserve the right to scrutineer any component or vehicle in the presence of the permanent Licenced Eligibility Scrutineer and one other scrutineer at the Ginetta Cars Ltd workshop or at a service partners premises. An invited member of the team may also be present. Removal of components from the car may be required at the Event or at the Ginetta Cars Ltd workshop at the discretion of the Licenced Eligibility Scrutineer. After thorough scrutineering of the parts the result will be submitted to the Championship Clerk of the Course.
- 3.3.10 In the case of a breach of the Technical Regulations or a breach of the procedure surrounding the Technical Regulations any costs associated with scrutineering and/or eligibility inspections (including but not limited to transportation checks inspections rebuilds etc.) will be the sole responsibility of the Entrant.
- 3.3.11 The assembly and dismantling of the vehicle(s) is solely the responsibility of the Entrant(s). Reimbursement of expenses for these measures may not be claimed. Exceptions to this may include appeal / protest according to the current Motorsport UK General Regulations.
- 3.3.12 The Championship Organisers may nominate from time to time and in their entire discretion a rolling road and / or rolling road dyno truck that may be used to assist the Licenced Eligibility Scrutineer and / or the Organisers. At any time, the Organisers or Licenced Eligibility Scrutineer reserve the right to test a vehicle on the nominated rolling road dyno machine and may use any data from the rolling road dyno machine as guidance and to assist with their determination of eligibility. Competitors / entrants must be willing to sign any associated indemnities to allow their car to be tested on the dyno.
- 3.3.13 In the event of a car being dyno tested after a qualifying session or race the driver/ Entrant/Team will be informed by the Licenced Eligibility Scrutineer. The car must then be

left in Parc Fermé until it is collected by a designated Ginetta official.

### **3.4 QUALIFYING**

- 3.4.1 The minimum period of qualifying to be provided at all events will be twenty minutes. Should any Qualifying Session be disrupted the Clerk of the Course shall not be obliged to resume or re-run sessions and the decision of the Clerk of the Course shall be final.

### **3.5 QUALIFICATION CRITERIA**

- 3.5.1 Any competitor who has not raced over the course in its current layout within the preceding 12 months must complete three practice laps in the car to be raced in order to satisfy the Clerk of the Course as to his competence. The Clerk of the Course and/or Stewards of the Meeting shall have the right to disqualify any competitor whose qualifying times and / or driving are considered to be unsatisfactory as per Motorsport UK Regulations.
- 3.5.2 Each driver's fastest qualifying time will determine the grid for the first Championship race at each Event. Each driver's second fastest qualifying time will determine the grid for the second Championship race at this Event. The starting grid for the third race (where one is scheduled) will be formed from the finishing order of the second race, as published by the official timekeepers. Competitors not classified as finishers in the second race will be placed on the starting grid for the third race after the last classified competitor according to the number of laps covered.
- 3.5.3 For the Anglesey Ginetta Festival, there will be ONE qualifying session and TWO races on each day, Saturday and Sunday. Each driver's fastest qualifying time will determine the grid for the first Championship race at each Event. Each driver's second fastest qualifying time will determine the grid for the second Championship race at this Event.
- 3.5.4 During the course of the qualifying session, ANY laps where the competitor is judged to have contravened track limits regulations as stated in the current Motorsport UK Year Book may be subject to a penalty as per the Motorsport UK Regulations. This may be applied retrospectively after the session is completed.
- 3.5.5 During the course of any qualifying session all competing cars must remain in the Pit Lane while not on the track. At no time will any competing car be allowed in the Pit Garages or Paddock areas until such time as the qualifying session has ended and the car cleared from any post-qualifying scrutineering checks and released from Parc Fermé except with the express permission of the Championship Clerk of the Course.
- 3.5.6 After taking the Chequered Flag competitors are required to progressively and safely slow down remain behind any competitor's ahead of them and proceed directly to the designated Parc Fermé area without stopping unless directed by an Official of the Meeting. Cars must remain in the designated Parc Fermé area until formally released by the Licenced Eligibility Scrutineer.
- 3.5.7 Any stationary cars in the Pit Lane at the end of a qualifying session come under Parc Fermé conditions at the showing of the Chequered Flag and should be taken directly to the designated Parc Fermé area.
- 3.5.8 Where through force majeure it is not possible to hold a qualifying session the grid for that race will be formed according to the current Championship driver standings. Where there is a tie on points the competitor with the best result in the previous round will take priority. In either case cars in the Rookie class will be placed at the rear of their own Championship grid.
- 3.5.9 In the event of a partial qualifying session being run grid order for any competitor who

failed to set a time will be formed at the rear of the grid and based on Championship driver standings.

- 3.5.10 In the event of Qualifying not being ran at the first round of the Championship the grid will be formed based on Championship race number in ascending order for race one and will then be reversed for race two. In the event of a third race the finishing order from race two will form the grid.

### **3.6 RACES**

- 3.6.1 The standard minimum scheduled race distance shall be 20 minutes. However, should any race distance be reduced at the discretion of the Clerk of the Course or Stewards of the Meeting it shall still count as a full points scoring round.
- 3.6.2 When in wet conditions the rearward facing red warning lights must be illuminated if the car has such a light fitted.
- 3.6.3 If weather conditions significantly change after leaving the Assembly Area and before the race start the start will be delayed and Entrants/Drivers will be allowed to change onto the eligible wet tyre. The maximum delay will be 10 minutes before the 2 minutes countdown board is shown.

### **3.7 STARTS**

- 3.7.1 All race start countdowns are to have a minimum elapsed period of 5 minutes from the time that all cars are released to form up on the grid to the start of the race in the formation as specified on the Track Licence for each circuit.
- 3.7.2 When the signal is given the cars will be released on to the circuit behind the Championship Safety Car and led to the grid. Once the train of cars following the Safety Car has left the Assembly Area and Pit Lane Exit will be closed. The cars will keep in formation with no overtaking. The Safety Car will set the pace. No practice starts may be executed during the course of this lap. Any car unable to join the train of cars following the Safety Car shall be held in the Pit Lane and may only start the race after the last car to take the start has passed the Pit Lane Exit on the first racing lap but shall only do so under the instruction of the Pit Lane Marshals.
- 3.7.3 It is not permitted to carry out any mechanical repairs on a car once formed on the grid including changing any tyres.
- 3.7.4 All starts will be Rolling Starts and grids will be determined in a 2 x 2 formation: The countdown procedures/audible warnings sequence shall be:
- 1 minute to start of Green Flag/Pace Lap - Start engines/Clear Grid
  - 30 seconds - Visible/audible warning start of Green Flag Lap imminent
  - Green Flag- Start of green flag/pace lap
- 3.7.5 Any cars removed from the grid after the 1 minute signal is given or driven into the pits on the Green Flag Lap shall be held in the pit-lane and may start the race after the last car has passed the start line or the pit-lane exit whichever is the later.
- 3.7.6 Any drivers unable to start the Green Flag/Pace Lap or Race Start are required to indicate their situation as per Motorsport UK Regulation Q12.11.2. and any drivers unable to maintain their grid positions on the Green Flag Lap to the extent that ALL other cars are ahead of them may complete the Green Flag Lap but MUST remain at the rear of the last row of the grid but ahead of any cars to be started with a time delay.

- 3.7.7 Upon the green flag, cars will begin the formation lap behind the safety car maintaining their starting order. During this lap practice starts are forbidden and the formation must be kept as tight as possible, excessive weaving to warm up tyres (using more than 50% of the track width) and falling back in order to accelerate is prohibited.
- 3.7.8 Overtaking during the formation lap is forbidden unless a car is delayed leaving its grid position and cars cannot avoid overtaking it without delaying the remainder of the field. In this case, Drivers may overtake only to re-establish the original starting order. Any Driver delayed in this way and who is unable to re-establish the original starting order before crossing the Intermediate Timing Point 2 or another location advised by the Clerk of the Course briefing notes for the Event must drop to the back of the entire grid and start the race from there.
- 3.7.9 Any Driver who is delayed leaving the grid and is stationary after the remainder of the cars have crossed the Line must not overtake another moving car and must start the race from the back of the grid. If more than one Driver is affected, they must start the race from the back of the grid in the order in which they left to complete the formation lap. If the Line is not situated in front of pole position, for the purpose of this Article only, it will be deemed to be the white line one metre in front of pole position.
- 3.7.10 A penalty will be imposed on any Driver who, in the opinion of the Clerk of the Course, unnecessarily overtook another car during the formation lap.
- 3.7.11 The speed of the Safety Car will be determined by the Clerk of the Course for the formation lap.
- 3.7.12 If conditions so require, the Clerk of the Course may ask the Safety Car to cover one or more additional formation laps. In that case, the start of the race, for the sole purpose of race distance, is considered as having been given at the end of the first formation lap.
- 3.7.13 Drivers in their cars must keep the formation as tight as possible maintaining the distance from the cars in front until they have crossed the start line after the start signal has been given. Once all cars are lined up side-side for the start, the Safety Car will pull off the track into the pit lane at the end of the [last] formation lap. The car in Pole Position must maintain its speed until the start signal is given. Unless otherwise specified in the briefing, the start signal will be given by turning off the red lights.
- 3.7.14 During the formation lap the red light will be on. No car may overtake another one before the starting signal is given.
- 3.7.15 There will be a rolling start in accordance with NCR Q.12.9.11(b). Race timing will commence at the point that the cars cross the start line.
- 3.7.16 The Organisers reserve the right to change the start procedure at any time, by confirmation of an Official bulletin.
- 3.7.17 Any driver adjudged to have committed a False Start or breached any part of the Start Procedure will be penalised by the addition of 10 seconds to the time taken to complete course.
- 3.7.18 In the exceptional circumstance, the race may be started behind the Safety Car. In this case, when the green lights are illuminated or a green flag is displayed at the start line, the Safety Car will leave the grid with its orange light illuminated and all competition cars following in grid order no more than 5 car length apart. All other marshal's posts and/or circuit light panels will display a Safety Car Board and Yellow Flag, which will be the signal to the Drivers that the race will be started behind the Safety Car. There will be no formation lap and the

race will start when the green lights are illuminated, or a green flag is displayed at the start line. Motorsport UK Regulations shall apply with regards to the end of the safety car period.

### **3.8 START DELAYED PROCEDURE**

3.8.1 If the starter deems that the start needs to be delayed, they will display a "Start Delayed" board. The Countdown Procedure/Audible Warning sequence will then recommence from the one-minute board and the race may be started by use of the National Flag if all Drivers have been informed of the change of start signal.

3.8.2 Any Driver(s) deemed to have caused an aborted start will be moved to the back of the grid but ahead of any cars to be started with a time delay. Depending on individual circuit layout the car(s) will either be removed to the back of the grid before the Green Flag Lap commences or the driver(s) will be instructed to commence the Green Flag Lap from his/her original grid position but must during the course of the Green Flag Lap allow any car(s) starting behind them to overtake thus ensuring that they take the restart from the back of the grid (but ahead of any car(s) to be started with a time delay). If more than one car is penalised in this way, then their order at the back of the grid will reflect their original grid positions. The onus is on the Driver to comply and failure to do so will result in a report to the Championship Clerk of the Course who may impose a Drive Through Penalty or retrospective 30-second time penalty.

3.8.3 Aborted start procedure will be as follows:

- The start-delayed board is displayed engines may be switched off and team members are allowed back onto the grid.
- When the Operations Clerk and Championship Clerk of the Course are happy the countdown restarts from the one-minute signal and the grid cleared in the usual way.
- Any car(s) that then cannot be started will be pushed to the side of the track (or Pit Lane if practical) and covered by a waved Yellow Flag. If any such car(s) at the side of the track can start unaided it may join the Green Flag Lap under the usual restrictions.
- The remaining cars are waved off on a Green Flag Lap.
- Any stalled cars are cleared to the Pit Lane if possible or if not to a place of safety. Cars once within the Pit Lane may be assisted by their team but may only start the race after the last car has taken the start and passed the Pit Lane Exit on the first racing lap.
- The race is started if appropriate upon return from the Green Flag Lap in the usual way. If one Green Flag Lap has already been completed before the 'start delayed' board is shown, then the race is reduced by 1 (one) lap. Then if the start is delayed again and another lap is lost or if this causes issues with the running of the timetable the Championship Clerk of the Course will set a new race distance.

### **3.9 RACE STOPS**

3.9.1 Should the need arise to stop any race RED LIGHTS will be switched on at the start line and RED FLAGS will be displayed at the start line and at all Marshals Signalling Points around the Circuit.

This is the signal for all drivers to cease circulating at racing speeds to slow to a safe and reasonable pace and return to the starting grid area which will automatically become a Parc Fermé Area. Cars may not enter the Pits unless directed to do so. Work on cars already in the Pits must cease when a race is stopped.

3.9.2 **Case A** - Less than two laps completed by Race Leader:

The race will be declared a "No Contest" and available competitors will restart from their



original grid positions Competitors unable to take the restart may be replaced by reserves who will start from the back of the grid in reserve order. Gaps on the grid should not be closed up. The Clerk of the Course may order that the duration of the re-run of any race shall be a shorter distance than originally scheduled or may be abandoned altogether. The duration of the re-run will be determined as the duration of the race.

**3.9.3 Case B** - More than two laps completed by Race Leader but less than 75% of race duration completed:

Any race stopped after the leader has completed more than two laps but less than 75% of its duration will be considered as the first part of the race. Competitors will be restarted from a grid set out in the finishing order of this first part, which shall be based upon the order of crossing the finish line at one lap less than the number of laps completed by the leader at the time of first showing the Red Flag. Only vehicles which are proceeding under their own power, in accordance with NCR Q.12.24.3(j) at the showing of the Red Flag will be classified in this first part (NCR Q.12.15.3, Q.12.15.6 and Q.12.16 also apply). The result of the race will be the finishing order at the end of the restarted race (see NCR Q.12.15.4).

Parc Fermé conditions will apply on the grid and to cars already in the Pits between the two parts of the race. The only work permitted on the cars will be on the grounds of safety and only with the permission of the Eligibility / Safety Scrutineer.

**3.9.4 Case C** - The leader has completed more than 75% of the race distance or duration.

If the leader has completed more than 75% of the race distance or duration it shall not be restarted and the results will be declared in accordance with Motorsport UK Regulation Q12.15.5, unless the Clerk of the Course, in consultation with the Stewards deems it appropriate to restart the race.

**3.9.5** In the event of a restarted race Motorsport UK regulation Q12.16 will apply to any repairs to cars required during the interval.

**3.9.6** Entrants/Drivers are advised that two Red Flag race stoppages in any one round may result in their race being placed at the end of the day's racing time permitting. Similarly, Entrants/Drivers are advised that should the timetable be running late their race may be postponed until later in the timetable to allow for a SRO race to start at its scheduled start time and/or their scheduled race distance may be reduced by the Championship Clerk of the Course in consultation with the SRO Coordinator and with the approval of the Stewards of the Meeting.

**3.9.7** If a race cannot be run or re-started at a venue for any reason, then at the Organisers entire discretion reasonable attempts will be made to provide a substitute race at another event but the Organisers are not contractually bound to provide such substituted race(s) and no refund of any Registration Fee shall be payable and with such occurrence of loss of race(s) being deemed force majeure. Any such substitute race will utilise the original grid and only competitors detailed on the original grid sheet will be eligible to participate.

### **3.10 RE-SCRUTINY / DRIVER AVAILABILITY**

**3.10.1** Any vehicle involved in an accident or having been modified in any way subsequent to pre- event scrutiny must be re-presented to the Licenced Eligibility Scrutineer for further examination.

**3.10.2** At any time during an Event the Organisers acting through the designated Clerk of the Course may order that a vehicle be re-examined even if this involves stopping a vehicle while qualifying or racing. Failure to comply with Regulations during a qualifying session

or failure to comply with the directions of race officials to undertake a check will result in the loss of that Driver's qualifying times to that point in the session.

- 3.10.3 If a Driver is involved in a collision or incident, they must not leave the circuit (except where medically evacuated) without the consent of the Championship Clerk of the Course failing which any judicial action against or relating to that Entrant / Driver may be heard in their absence.
- 3.10.4 Entrants / Drivers must remain available at an Event until any protest period relating to their race has elapsed failing which any judicial action against or relating to that Entrant/Driver may be heard in their absence.
- 3.10.5 Entrants' / Drivers' cars may not be removed from the Paddock during an Event after initial scrutineering except for the purpose of competing in the rounds comprised in the Event or with the prior written permission of the Licenced Eligibility Scrutineer and Championship Clerk of the Course. The Organisers and /or Licenced Eligibility Scrutineer may require the Entrant's/Driver's car to be re-scrutineered at any time.

### **3.11 PITS & PIT-LANE SAFETY**

- 3.11.1 Pits: Entrants must ensure that the Motorsport UK Circuit Management and Organising Club Safety Regulations are complied with at all times.
- 3.11.2 Pit-lane: The outer lane or lanes are to be kept unobstructed to allow safe passage of cars at all times. The onus shall be on all drivers to take all due care and drive at minimum speeds in pit-lanes. During qualifying sessions and races Drivers leaving the Pit Lane will do so on their own responsibility however a marshal with a Blue Flag will warn of cars approaching.
- 3.11.3 Refuelling: There is no refuelling to be carried out during any official Ginetta sessions.
- 3.11.4 Speed Limit: The Pit Lane Speed Limit during each Meeting and official test day will be as per final instructions.
- 3.11.5 The Penalty will be a Drive through Penalty in the race but if the infringement is notified to the Championship Clerk of the Course after the end of a race they may levy a fine of £10 for each Km/h above the speed limit (this penalty will apply for qualifying) or impose a retrospective time penalty. Signs and /or lines are used to indicate the beginning and end of the area to which the speed limit applies.

### **3.12 RACE FINISHES**

- 3.12.1 After taking the Chequered Flag drivers are required to:  
Progressively and safely slow down remain behind any competitors ahead of them return to the Pit-lane Entrance going directly to Parc Fermé as instructed comply with any directions given by Marshals or Officials and keeping helmets on and harnesses done up while on the circuit or in the pit-lane and should remain in Parc Fermé with their cars until released by the Licenced Eligibility Scrutineer or are required for Podium Presentations.
- 3.12.2 Parc Fermé Regulations will apply to the area between the Start / Finish Line and the Parc Fermé entrance. Any area deemed necessary by the Series Eligibility/Safety Scrutineer and/or his nominated representative will be subject to Parc Fermé conditions with no exceptions.
- 3.12.3 Once in the Parc Fermé area Drivers required for the podium presentations must proceed immediately to the podium. The Drivers required will be those finishing first second and third in each class.
- 3.12.4 Team personnel are only allowed into the Parc Fermé area at the invitation of the Licenced

Eligibility Scrutineer. Should unauthorised team personnel be present in Parc Fermé they render their car liable to disqualification from the Event. Any breach to Parc Fermé regs will be reported to the Clerk who may impose penalties as appropriate. On request of the Series Eligibility / Safety Scrutineer the Parent or Legal Guardian of the driver will be permitted in Parc Fermé.

### **3.13 RESULTS**

- 3.13.1 All Practice Timesheets Grids Race Results are to be deemed PROVISIONAL until all vehicles are released by the Licenced Eligibility Scrutineer after Post Practice / Race Scrutineering and/or after completion of any Judicial or Technical Procedures. The Championship Clerk of the Course may declare the race results provisional until any investigation of video or other evidence has been completed and subsequent judicial procedures undertaken regardless of whether this investigation is as a result of a protest or merely a result of establishing if a Regulation has been broken. These results will remain provisional until such time as they are declared final by the Championship Clerk of the Course upon completion of any judicial procedures, and this will be communicated to all Entrants / Drivers via a Championship bulletin.

### **3.14 TIMING MODULES**

- 3.14.1 All competitors will be required to fit an Electronic Self Identification Module (Transponder) as per Q12.8.1. to their cars for the purposes of accurate timing. Holders for these and detailed fitting instructions will be issued with the transponders, and it will be the responsibility of the competitor to fit these in the car in the position and manner specified. The Modules must be in place and functioning correctly for all Championship qualifying practice sessions and races. The setting and servicing of these items must only be carried out by properly authorised Motorsport UK licensed Timekeepers. Competitors will be charged by the timing company for replacement of the Modules due to misuse or loss at any time during the season.
- 3.14.2 Competitors may not place electronic timing equipment within five metres of the official Start Finish or any other official timing lines at any event or test session/day. Any such equipment placed within these zones will be removed.

### **3.15 DIFFICULTY**

- 3.15.1 If any Driver experiences a serious mechanical problem at any stage, they must leave the track as soon as it is safe to do so and park in a position of relative safety. The car must be left in neutral, and any removable steering wheel must be reattached before the Driver gets behind the protective safety barriers. The Driver should stay with the car to assist recovery crews with the task of bringing the car back to the pits at the end of the session.

### **3.16 ASSISTANCE**

- 3.16.1 Regardless of the circumstances once a Driver has received mechanical assistance to move his/her car from one position to another they is not permitted to continue within that particular session or race even if after being moved into a position of safety they feel they are able to continue.

### **3.17 SPARE CARS**

- 3.17.1 Replacement cars may only be permitted with the express permission of the Clerk of the Course and a Championship Coordinator. The presentation of a spare car for scrutineering must be done in accordance with the regulations set out within the current Motorsport UK General Regulations. A competitor using a replacement car where permitted will incur a 20 point reduction in the Championship points.

3.17.2 A replacement car is considered to be any car other than that which was first presented by the Entrant at and scrutineered for a particular Event.

### **3.18 SAFETY CAR**

3.18.1 The Safety Car will be brought into operation and run in accordance with Section Q, Appendix 3 of the Motorsport UK General Regulations.

### **3.19 DRIVING STANDARDS**

3.19.1 Any competitor who is reported to be involved in cases of contact which in the opinion of Officials is avoidable may be subject to the following immediate penalties:

3.19.2 During practice and / or qualifying: The competitor concerned may be Black Flagged and subsequently may be prevented from taking any further part in that session.

3.19.3 During race: The competitor concerned may be penalised by way of a drive through penalty in accordance with Motorsport UK General Regulation Q12.26.

3.19.4 A drive through penalty being imposed will be notified by the use of a Black Flag and Penalty Board and must be taken within 3 laps of the notification being given. It will involve the competitor entering the pit-lane observing the pit-lane speed limit between the 'in' and 'out' control lines and exiting the pit-lane to re-join the race without stopping at their pit.

3.19.5 Failure to comply with the imposition of a drive through penalty may result in disqualification from the race in question.

3.19.6 In the event that a penalty described above cannot be imposed for operational reasons during a race the competitor concerned may be given a 30 second elapsed time penalty (and relative Licence Penalty Points) as an alternative.

3.19.7 Any competitor who exceeds the limit of the track should only re-join when safe to do so and without gaining an advantage. Any competitor who is deemed to have gained an advantage or repeatedly exceeds the track limits may be penalised by way of a 'Drive Through' or 'Stop / Go' penalty in accordance with Motorsport UK General Regulation Q12.26.

3.19.8 In addition to a 'Drive Through' or 'Stop / Go' penalty the competitor may also be subject to penalties in accordance with Motorsport UK General Regulation Q12.26.

3.19.9 The Organisers will meet following each race weekend to assess all on and off track incidents.

3.19.10 The Organisers will use any evidence available to them to request that the Championship Stewards investigate any drivers who are deemed to show poor driving standards or bring the Championship into disrepute in any such manner through on and / or off track incidents. In addition, the Organisers shall be entitled to revoke any relevant Registration.

3.19.11 The Championship Stewards have the ability to impose and enforce Championship penalties affecting Championship points and potential refusal of race entries in the way of race suspensions. Penalties made through the Championships Stewards may be in addition to any penalties made by the race Officials.

3.19.12 Any evidence available to the Championships Stewards such as observers reports and video evidence may be used to support the imposition of penalties.

### **3.20 ADDITIONAL SPORTING REGULATIONS ISSUED FOR THE CHAMPIONSHIP**

3.20.1 The organisers of the Ginetta GT Academy Championship are determined to create a

Championship which is cleanly fought and with good sporting behaviour prevailing.

- 3.20.2 Breaches of driving standards will be firmly dealt with. If the Championship Clerk of the Course wishes to view any video evidence and / or data logging evidence in order to assist with his enquiry into a breach of driving standards he may order that the results remain provisional and he may take judicial action at a later date. However, the use of video evidence and/or data logging evidence in all circumstances is at the sole discretion of the Championship Clerk of the Course.
- 3.20.3 Any driver found guilty of a driving offence which generates penalty points under the Motorsport UK General Regulations will also have Championship points deducted proportional with the severity of penalty imposed. Any deduction of Championship points will be three times that of the associated licence penalty points. i.e. formal written reprimand 6 points, fine, grid place penalty or time penalty 9 points, disqualification from practice heat or race 12 points, disqualification from meeting 18 points.
- 3.20.4 In addition to the penalties laid down the Championship Stewards are empowered to deduct Championship points if the driving conduct of the driver or the general conduct of any person associated with the entrant/driver's entry is deemed by the Organisers in their absolute discretion to be unacceptable and the Championship Stewards are empowered to revoke Championship Registration.
- 3.20.5 Each Entrant/Driver is required to have one fire extinguisher per car (minimum capacity 5kg or its equivalent) within their transporter/awning at each Event. This shall not include the extinguisher fitted to the car(s).

### **3.21 CAMERAS**

- 3.21.1 All cars must carry two Championship on-board Judicial camera during all official qualifying sessions and races. [see J5.21]. It is the entrant's responsibility to ensure that the judicial cameras are fitted and operational during all official qualifying and races, and that the footage produced is of an acceptable quality. One Camera must be a Go Pro (3.21.2) and the other camera must be with a combined data logging system (3.21.3). The judicial cameras must be positioned in the centre of the vehicle and must be mounted so to capture an image that provides a 'drivers eye' view that include driver input (i.e. steering), dashboard and full view of the circuit ahead with a field of vision of approximately 100 degrees. All Go Pro, Vbox and Aim are to be permanently on and recording from the time that the car leaves the assembly area.
- 3.21.2 Mandatory judicial cameras for use within the Championship is as follows:
- Any Go Pro variant from the Hero 2 range or newer
- 3.21.3 One additional camera/data system must be installed in the car along with the mandatory Go Pro above. The following camera are:
- Vbox data logging system
  - Aim Smarty Cam
- 3.21.4 The camera data storage device (data card) will be distributed by a Ginetta official prior to qualifying and races. The onus is on the competitor to ensure the cards are fitted and the Judicial cameras are switched on and recording for all official qualifying sessions and races. For any camera which is not switched on or has not produced acceptable footage, the Competitor will incur a fine of £250 for each and every offence.
- 3.21.5 It is the responsibility of the competitor/entrant to supply Ginetta with EIGHT SD/data cards (FOUR micro SD cards and FOUR SD cards) that are compatible with the judicial cameras fitted in the competitors car prior to the start of the season.

- 3.21.6 Judicial cameras must be switched on but not before three minutes prior to leaving the assembly area. All Data Cards will be collected by a Ginetta Representative or other officials after the end of each session in order for the Clerk of the Course to review footage. Data cards are to remain in the car until collected by a Ginetta Representative or other official. Any entrant/driver that fails to comply will be reported to the Clerk of the Course and may result in a penalty during the event. The video/images remain the property of Ginetta Cars LTD and it is not to be used on Social Media or for any other public use.
- 3.21.7 During qualifying and races the only cameras permitted in the car will be the official judicial cameras as supplied by Ginetta. The only exception to this will be a camera fitted by the television production company in accordance with Commercial Regulations **8.8**. This footage is to be used for judicial purposes it is at the sole discretion of the Clerk of the Course as to whether competitors will have access to this footage after judicial procedures have been completed.

## **4. CHAMPIONSHIP RACE PENALTIES**

### **4.1 INFRINGEMENTS OF TECHNICAL REGULATIONS**

- 4.1.1 Arising from post practice Scrutineering or Judicial Action:  
(a) Minimum Penalty: The provisions of Motorsport UK Regulation C3.3
- 4.1.2 Arising from post race Scrutineering or Judicial Action:  
(a) Minimum Penalty: The provisions of Motorsport UK Regulation C3.5.1. (a) and (b).
- 4.1.3 For infringements deemed to be of a more serious nature the Clerk of the Course and/or the Stewards of the Meeting are to invoke the provisions of Motorsport UK Regulation C3.5.1. (c).
- 4.1.4 Further penalties may be imposed by the Championship Stewards as outlined within these regulations.

### **4.2 INFRINGEMENTS OF NON-TECHNICAL MOTORSPORT UK REGULATIONS AND THE SPORTING REGULATIONS ISSUED FOR THE CHAMPIONSHIP.**

- 4.2.1 As per current Motorsport UK Judicial Procedure Regulations and these Championship Regulations.
- 4.2.2 Up to a 10 Grid Place Penalty may be applied at a driver's future Race in accordance with Motorsport UK Regulations.

### **4.3 BEHAVIOURAL POINTS**

- 4.3.1 Drivers involved in incidents of any kind, or who have been reported for poor sporting behaviour or driving standards, may be awarded Behaviour Points by the Clerk.
- 4.3.2 The following may apply, subject to the decision of the Clerk of the Course:
- Reprimand - 1 Behaviour Point
  - Pit lane speeding - 1 or 2 Behaviour Points depending on the severity of the offence
  - Causing a collision 1 or 2 Behaviour Points depending on the severity of the offence
  - Other offences may give rise to Behaviour Points as decided by the Clerk.
- 4.3.3 The number of Behaviour Points will be calculated per driver and the following penalties imposed:
- A driver with 3 points will receive a 5 place grid penalty
  - A driver with 6 points will receive a 10 place grid penalty
  - A driver with 9 points will receive a 10 place grid penalty and -15 championship points
  - A driver with 12 points or more will receive a 10 place grid penalty and -35 championship points
- 4.3.4 Behavioural points can also be imposed to Entrants (Teams), The following may apply, subject to the decision of the Clerk of the Course:
- Warning – 1 Behavioural Points
  - Abusive language or Behaviour – 2 behavioural points
  - Other offences may give rise to Behaviour Points as decided by the Clerk.
- 4.3.5 The number of Behaviour Points will be calculated per Entrant (Team) the following penalties imposed:

- An Entrant (Team) with 2 points will receive a £100 fine
- An Entrant (Team) with 4 points will receive a £500 fine
- An Entrant (Team) with 6 points will receive a £1000 fine



## **5. TECHNICAL REGULATIONS – GENERAL**

### **5.1 INTRODUCTION**

- 5.1.1 The following Technical Regulations are set out in accordance with the Motorsport UK specified format.
- 5.1.2 Everything that is not explicitly authorised and anything that is not specified:
- in these regulations
  - in any official technical bulletin that may be published
- is strictly forbidden.
- 5.1.3 Any issue howsoever touching upon the conformity to the class specification of a car or any component within a car shall be determined definitively by a certificate under the authority of Ginetta Cars Ltd including any matter arising as a consequence of any technical or eligibility examination of the car by or on behalf of the Organisers for all purposes under these Championship Regulations and the Motorsport UK General regulations.
- 5.1.4 Each Ginetta race car is manufactured to an identical class specification. In the interests of fairness and safety competitors may not depart from this specification under any circumstances other than as specified within these Championship Regulations.
- 5.1.5 Except as may be permitted expressly by these Regulations or in writing by Ginetta Cars Ltd on behalf of the Organiser no car shall use or have affixed to it any pattern or aftermarket component as part of or in substitution for the class specification of the car and its components.
- 5.1.6 All Ginetta manufactured parts and in particular body panels must be supplied by Ginetta Cars Ltd (or in the case of force majeure a supplier nominated by the organisers) and fitted in their original position. Entrants and Team are reminded that the car and all Ginetta parts are the intellectual property of Ginetta and interference with those rights shall be a breach of these Championship Regulations including the Commercial Regulations and without limitation of rights vested in Ginetta will lead to revocation of Championship Registration.
- 5.1.7 Whilst the Licenced Eligibility Scrutineer is empowered to check all competing vehicles for compliance and has been provided with the data to determine the continuing eligibility of each car the onus of responsibility for the eligibility of vehicles competing in this Championship rests with the Entrant / Competitor. In the event of a dispute concerning the compliance of a vehicle with these Regulations the onus is on the Entrant / Team / Competitor to satisfy the Organisers with regard to such compliance and NOT the Organisers to prove non-compliance.
- 5.1.8 Where it is suspected that a component or structure fitted to the competing vehicle may render the vehicle ineligible under these regulations the component or access to the component will be sealed on behalf of the Organisers by the Licenced Eligibility Scrutineer for subsequent examination as directed by the Organisers. Where ineligibility is subsequently proven all points accrued by the competitor from and including the date of sealing the said component to the date of examination shall be forfeit in addition to any other penalty or penalties applied by the Organisers under or pursuant to these Regulations.
- 5.1.9 Where costs are incurred as a result of any eligibility check conducted either by the Licenced Eligibility Scrutineer or the Championship Organisers these will be borne by the

competitor / Entrant / Team and Championship Registration shall be suspended until such time as those fees have been paid as cleared funds regardless of any Judicial Appeal arising out of the eligibility examination.

- 5.1.10 As a method of control any component on a competitor's car may be removed by the Team/Driver at the request of the Licenced Eligibility Scrutineer and exchanged for a similar component from the car of another competitor or provided by the Championship Organisers. This includes the ECU. Whilst efforts will be made to ensure that the condition of the exchanged parts is similar responsibility for the care of exchanged components lies with the recipient. Exchanged components may be returned to their original owners on completion of the race.
- 5.1.11 Any infringement of these Technical Regulations will render the competitor liable without limitation to penalties provided by these Regulations including for the avoidance of doubt under the Commercial Regulations.
- 5.1.12 Cars will be issued at the start of each season with log books These will be used to record information relating to that car during the season. The entrant / driver of each car will be responsible for the safe keeping of the log book which shall be presented with the car at pre-event scrutineering.
- 5.1.13 IT MUST BE CLEARLY UNDERSTOOD THAT THE OVERRIDING PRINCIPLE OF THESE REGULATIONS IS THAT UNLESS IT IS STATED THAT YOU CAN DO IT YOU MUST WORK ON THE PRINCIPLE THAT YOU CANNOT.
- 5.1.14 Whilst Ginetta will endeavour to inform Competitors of any changes of components or part numbers they reserve the right to fit updated components during the life of these Regulations.
- 5.1.15 Lubricants – All cars competing within the Championship must use the lubricants specified and supplied by Ginetta with no additives of any kind. Details of the lubricants to be used will be communicated to all competitors via Championship bulleting prior to the start of the season.
- 5.1.16 Oil samples will be taken and analysed throughout the season in order to police this regulation. Non conformity will be treated as technical non-compliance and breach of the Commercial Regulations and may lead to revocation of Championship Registration(s).

## **5.2 GENERAL DESCRIPTION**

- 5.2.1 The 2024 GINETTA GT ACADEMY is a 'one make' race series for Ginetta 'GTA spec race cars as specified herein. Both right- and left-hand drive versions of the Ginetta GTA spec cars are eligible.
- 5.2.2 The parts used to build Ginetta GTA cars are categorised as below:  
These parts are divided into 3 categories.
- Category A: No modifications are permitted. Parts in this category must remain in their original location and fulfil the function/s for which they were originally designed.
  - Category B: Only such modifications as specified in the regulations
  - Category C: The part is considered to be unrestricted on the express condition that the function for which it was originally designed is not deviated from that it does not fulfil any additional function and that it is located in the same place as the original part.
- 5.2.3 Any query in respect of any technical matter arising out of or touching upon these Regulations must be put in writing to the Organisers for referral to the Licenced Eligibility Scrutineer and / or Ginetta'. The only clarifications rulings or permissions under these

Regulations that will be acknowledged by the Organisers must be substantiated by the production on demand of written confirmation of such clarifications, rulings or permissions.

### **5.3 NUMBERS AND DECALS**

- 5.3.1 All cars must carry Championship and Championship trade sponsor decals as required by the Organisers from time to time.
- 5.3.2 Each car must carry Championship decals as per the figure in **Appendix A**. Competitors will be supplied with three number squares incorporating the major sponsors logos. One must be affixed to each side of the car in the position normally occupied by the doors. The third must be located to the front / top aspect of the car so as to be clearly visible. Competition numbers must be affixed to these squares and to the front / top aspect of the car so as to be clearly visible.
- 5.3.3 Ginetta Cars may request at any point that additional Championship / trade sponsor decals are carried on cars. This will be done by way of an official Championship bulletin. The Championship organisers reserve the right to remove from any competing car any decals or branding which is deemed to be unsuitable or conflicts with other Championship / Ginetta sponsors.
- 5.3.4 Failure to comply with regulations **5.3.2** and **5.3.3** will not be subject to a technical non-compliance but will be liable to penalty under the Commercial Regulations for the Championship.

## 6. TECHNICAL REGULATIONS – GINETTA GTA

### 6.1 SAFETY REQUIREMENTS

6.1.1 The Ginetta GTA race car is manufactured to comply with the following safety requirements of Section K of the current Motorsport UK General Regulations and all which must be retained:

- K Roll cage with side and rear safety protection bars K2.1.4 Six Point safety harness.
- K3.1 Plumbed in current FIA Homologated fire extinguisher system. This system must be in the 'armed' condition (i.e. be capable of being operated without the removal of any safety device) at all times whilst competing or practicing. The fire extinguisher cannot be disarmed in any Parc Fermé area without the specific permission of the Licenced Eligibility Scrutineer. Any system found to be incapable of being operated by virtue of the imposition of a safety device (e.g. pin) having been made whilst the vehicle is either competing or in Parc Fermé will be subject to report to the Clerk of the Course for possible penalisation as an offence against Safety Regulations. The fire extinguisher must be serviced every two years by the manufacturer or the manufacturers agent to remain within its homologation. For the avoidance of doubt this means that only the above applies and not an alternative service facility or persons.
- K5 Two fog lamps which in the Ginetta are integral with the rear light cluster
- K6 Internal fuel filler that can be positively closed
- K8 External Circuit Breaker

6.1.2 The attention of all competitors is drawn to Articles K9 K10 and K11 of the Motorsport UK General Regulations relating to overalls crash helmet and visors.

6.1.3 The use of an FIA Homologated FHR (head and neck support systems) is compulsory. The helmet manufacturer must certify the tether anchorages and their mounting.

6.1.4 For clarification on clothing standards and for a list of approved helmets refer to the FIA website [www.fia.com](http://www.fia.com).

6.1.5 Any padding on the roll cage must comply with FIA standard 8857-2001 or such other standard as may replace that from time to time.

6.1.6 Roll cage padding (complying with FIA standard 8857-2001 subject as stated at Art.6.1.5 above) must be used on the sections of roll cage as shown in the diagram below (note left hand driver variants must apply padding to the equivalent location on the left side of the vehicle):

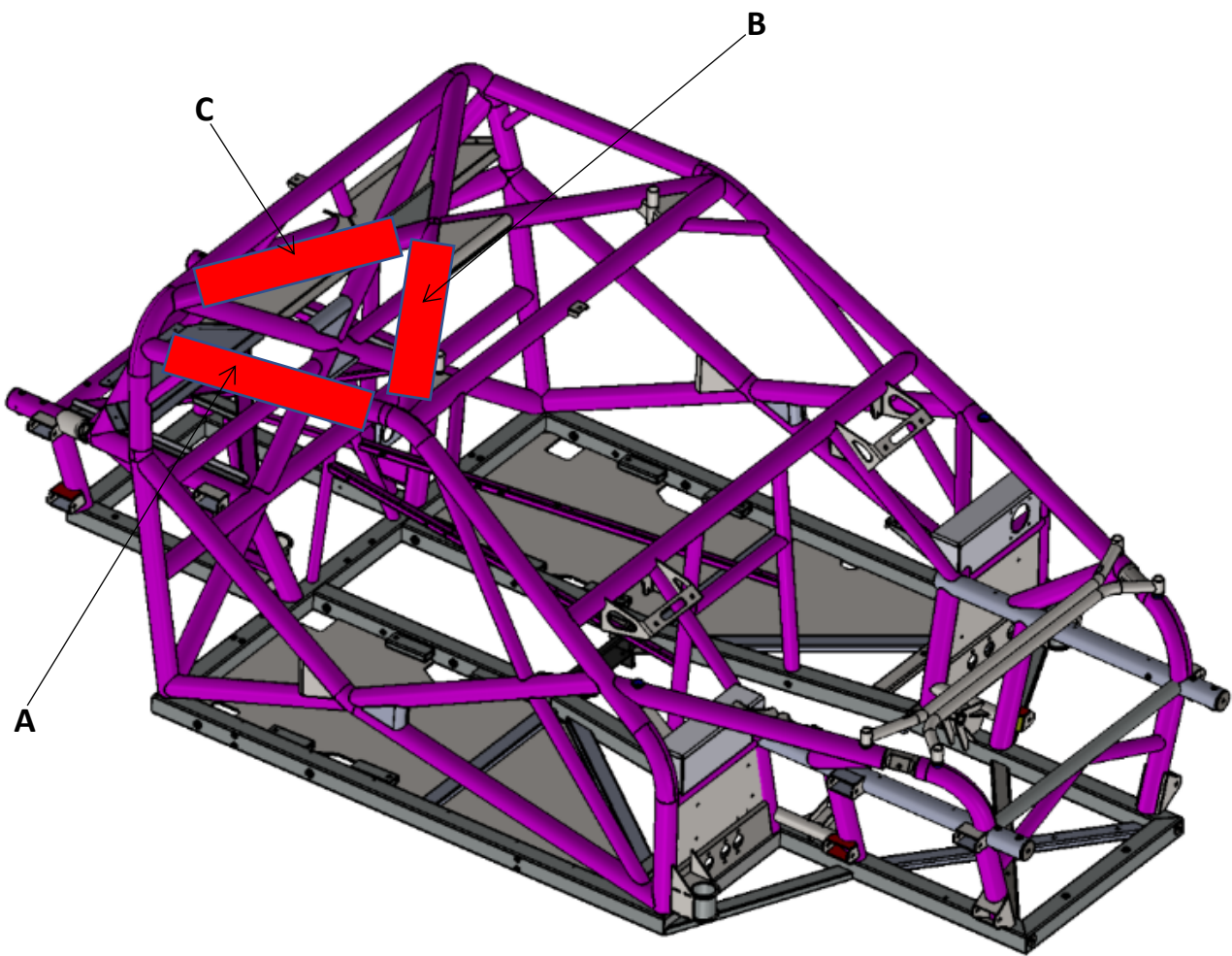

**Lengths of padding required:**

**A - 500mm**

**B - 450mm**

**C - 500mm**

## **6.2 GENERAL TECHNICAL REQUIREMENTS**

- 6.2.1 The Ginetta GTA race car is built to comply with the provisions of Sections J Tech (all vehicles) and Q (race vehicles) of the current Motorsport UK General Regulations. Competitors are reminded that a catch tank must be fitted and that the location of the vehicle towing eyes should be suitably marked.
- 6.2.2 From time to time it will be necessary to approve alternative equivalent components. Only components approved as alternatives and published as such by the Championship Organisers and/or their appointed representatives in official amendments to these regulations are eligible for the Championship.
- 6.2.3 In case of force majeure Ginetta Cars may at any time approve alternative components. Competitors will be notified of any changes to the regulations via a published bulletin. If alternative components are to be used these must be declared within the car's log book when the car is presented for scrutineering.

### **6.3 CHASSIS**

- 6.3.1 The Ginetta GTA car and chassis is manufactured to a standard specification and may not be altered. All chassis repair work must be undertaken only under the control and approval of Ginetta Cars Ltd. Breach of this Regulation may result in revocation of Championship Registration(s)

### **6.4 BODYWORK**

- 6.4.1 The Ginetta GTA race car body is manufactured to a standard specification. All body parts must be sourced and supplied exclusively through Ginetta Cars Ltd. Minor fibreglass repairs may be undertaken by the competitor provided that the body profile is not altered in any way. However, the Organisers reserve the right to reject any such repairs whether in the interests of safety technical conformity or Championship aesthetic and to require the Entrant, Team or Competitor to substitute the damaged repaired panel with a new panel sourced in accordance with this Regulation.
- 6.4.2 Additional ventilation holes may not be cut into the bodywork unless written consent has been given by Ginetta Cars Ltd and approved by the Licenced Eligibility Scrutineer.
- 6.4.3 A bodywork template/profile tool may be used by the Organisers at any time including but not exclusively at scrutineering to ensure that original shape and car profile is retained. No extra panelling either under floor or around the wheel arch area is permitted. The presentation of vehicle bodywork and repairs must be deemed acceptable by Ginetta Cars Ltd and the Championship Organisers in the interest of all cars being presented in a way representative of the Ginetta marque. It is not permitted to cover bodywork apertures and joint lines with adhesive tapes unless authorised by the Licenced Eligibility Scrutineer as a short-term repair.
- 6.4.4 It is not permitted to cover bodywork apertures and joint lines with adhesive tapes unless authorised by the Licenced Eligibility Scrutineer as a short-term repair. The only exception to this is the application of adhesive tape to cover a portion of the radiator aperture mesh but ensuring not to cover the power steering cooler. The tape must adhere to the mesh not the bodywork so as to not create an aerodynamic advantage.
- 6.4.5 The fitment of the mesh sill front end covers (Part Number G123B-0175NP, G123B-0173NP & G123B-0131LP) must be fitted to both left and right hand sides of the vehicle. Rear covers (Part number-G55- B0261/B0262) must also be fitted both covers must be supplied by Ginetta Cars. Additional covers may be added but must be checked by the Licenced Eligibility Scrutineer before permitted for use.
- 6.4.6 Door mirrors (part numbers G55-B0509 & G55-B0510) must be fitted, and remain in their original positions. It is permissible to use an alternative central rear-view mirror to the one supplied by Ginetta Cars.
- 6.4.7 The driver's seat is fixed and in compliance with Motorsport UK General Regulation K 2.2 (Ginetta part number G40-Q0092 or upgraded to G40-Q0110). Drivers may change their seat only with written confirmation from the Championship Organisers. A FIA Homologated and in date seat must be fitted.
- 6.4.8 A standard front screen as supplied by Ginetta Cars Ltd must be fitted. (Ginetta part number G123B-0064NP.00)
- 6.4.9 The rear bumper vents must be covered with mesh as supplied by Ginetta cars. Alternative mesh may not be used. Part number G55-B0138 & G55-B0139
- 6.4.10 The front bumper lower metal guard must remain positioned directly to the front bumper. The front bumper should be fitted directly to the crash box.

## **6.5 REAR WING**

- 6.5.1 The Ginetta GTA race car must only use a rear wing aero kit as supplied by Ginetta Cars Ltd. All components of the rear wing kit must remain as standard and as supplied by Ginetta Cars Ltd and may not be altered in any way. No additional structures other than those permitted or mandated by Ginetta Cars Ltd are allowed.
- 6.5.2 Details of the rear wing kit are available from Ginetta.
- 6.5.3 The position angle and height of the rear wing is fixed for mounting of the wing stay to wing box positions. A template may be used to certify that no modifications have been made to any part of the rear wing kit. Wing stays must be fitted in position 4 of the wing box.
- 6.5.4 The fitment of the wing to the wing stays can be adjusted between holes A, B & C.
- 6.5.5 The fitment of a rear wing gurney is mandatory and must not be modified in any way from its standard size and shape.

## **6.6 PERMITTED ENGINE**

- 6.6.1 The following specifications are for information only and are not intended to and do not infer modification is in anyway allowed.
- 6.6.2 The Ginetta GTA Car is supplied with a current Ginetta Cars Ltd specification Ford 3.7 litre V6 engine or Ford 3.5 litre V6 engine, fitted with ancillaries built by Ginetta Cars Ltd and sealed by Ginetta Cars Ltd using Ginetta specific seals. Ginetta Cars Ltd will notify the Entrant of the location of the applied seals and will exclusively maintain a record of the locations and the seal numbers. The engine seals must remain intact and undamaged for the engine to be eligible to take part in official testing qualifying or racing events. It is the responsibility of the Competitor to ensure the security of the seals. Seals can only be removed by the Licenced Eligibility Scrutineer or approved agent of Ginetta Cars Ltd. All broken Seals are recorded and noted by the Championship Organiser and in the event of any seal being broken or in the absolute opinion of the Organisers having the appearance of having been tampered with then the engine shall be deemed by the Organisers ineligible in any event and shall be subject to inspection at exclusive cost to the Competitor payable as a debt. All relevant Championship Registrations shall be suspended until such time as the cost of inspection under this Regulation has been paid as cleared funds as directed by the Organisers.
- 6.6.3 Both Ford 3.7 and 3.5 V6 engines will be fitted with a sealed 40 mm inlet restrictor (Part number G123E-0257NA.00-A and G123E-0253NP.00) which must be installed with the supplied O ring as per the diagram below.

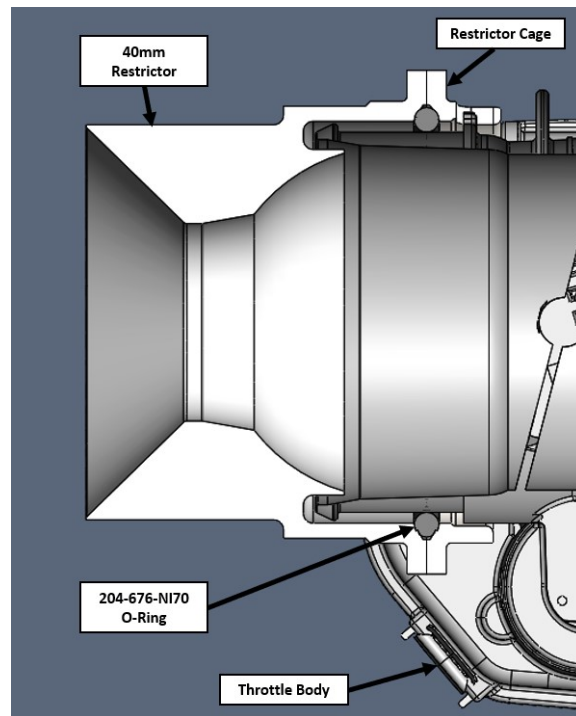

- 6.6.4 If the engine is damaged or worn it must be returned to Ginetta Cars for exchange or repair by Ginetta Cars Ltd at the competitor's cost. Any maintenance to the engine in an area not covered by the Seals must use original parts for this engine and which must be sourced exclusively from Ginetta Cars Ltd. In any dispute the part in question will be compared to the relevant part and/or drawing held by Ginetta Cars Ltd. All relevant Championship Registrations shall be suspended until such time as the cost of repair or replacement as the case may be under this Regulation has been paid to Ginetta Cars Ltd as cleared funds.
- 6.6.5 Engine Control Unit. (ECU) The cars are fitted with a MOTEC M150 or M142 ECU. These are fitted with a bespoke Fuel and Ignition map and Engine run data which are Password protected. The ECU must not be tampered with in any way. The ECU can be interrogated at any time during a race meeting at the request of the Organisers by the Licenced Eligibility Scrutineer or approved Ginetta Cars agent. The Championship Organisers reserve the right to exchange any Competitor's ECU with an Official Series spare.
- 6.6.6 Engine Wiring Loom. This must remain as supplied by Ginetta Cars Ltd with no modifications permitted.
- 6.6.7 Manifolds. It is permissible to use only inlet and exhaust manifolds as per part no. G55-F0006/G55-F0007 List as supplied by Ginetta Cars Ltd. Polishing abrasive cleaning or otherwise altering the manifolds internally is prohibited.
- 6.6.8 Catalytic Converters. A catalytic converter as supplied exclusively by Ginetta Cars Ltd must be fitted to each exhaust and must be working at all times and remain unmodified. Tests will be carried out to ensure compliance. Part no. G50-F0001.
- 6.6.9 Air Filter. This must be fitted at all times and remain as supplied by Ginetta Cars Ltd. Part no. G50-E0015.
- 6.6.10 Fuel Pressure. The fuel pressure regulator supplied with the car is the only eligible type. The fuel pressure must be 4.0 BAR +or-0.1 BAR. The fuel pressure will be checked regularly to ensure compliance. Part no. G55-M0104.
- 6.6.11 Spark Plugs. 3.7 V6 engines are supplied with Motorcraft Platinum CYFS12F-5 spark plugs.



These can be replaced using NGK PTR 5A-10 5055 plugs supplied by Ginetta Cars Ltd. Only these alternative spark plugs are eligible in the Championship. Part number GIN-V6-H-0014. 3.5 PFDI V6 engines are supplied with Motorcraft Platinum CYFS12YT6 spark plugs. These can be replaced using Bosch HR7N PP30V plugs supplied by Ginetta Cars Ltd. Only these alternative spark plugs are eligible in the Championship. Part no G123E-0233NP.00.

## **6.7 TRANSMISSION / FINAL DRIVE**

- 6.7.1 The Ginetta GTA race car must retain the Quaife 6 speed sequential gearbox with mandated for 2024 and onwards Ginetta straight cut gear ratios as supplied through Ginetta Cars Ltd. It is the competitor's responsibility to ensure that the following prescribed gear ratios are retained at all times during competition: 1<sup>st</sup> 2.057:1, 2<sup>nd</sup> 1.6:1, 3<sup>rd</sup> 1.333:1, 4<sup>th</sup> 1.150:1, 5<sup>th</sup> 1:1, 6<sup>th</sup> 0.889:1 Calculated including the drop gear ratio (total transmission ratio).
- 6.7.2 A Ginetta Cars Ltd supplied CWP & ATB limited slip differential with a final drive ratio of 3:73 must be used. This is the only allowable unit.
- 6.7.3 The sealed Gearbox and sealed differential may only be rebuilt by Ginetta Cars Ltd. Ginetta Cars Ltd will notify the Entrant of the location of the applied seals and will exclusively maintain a record of the locations and the seal numbers. The seals must remain intact and undamaged for the Gearbox and / or differential to be eligible to take part in official testing qualifying or racing events. It is the responsibility of the Competitor to ensure the security of the seals. Seals can only be removed by the Licenced Eligibility Scrutineer or approved agent of Ginetta Cars Ltd. All broken Seals are recorded and noted by the Championship Organiser and in the event of any seal being broken or in the absolute opinion of the Organisers having the appearance of having been tampered with then the relevant component shall be deemed by the Organisers ineligible in any event and shall be subject to inspection at exclusive cost to the Competitor payable as a debt. All relevant Championship Registrations shall be suspended until such time as the cost of inspection under this Regulation has been paid as cleared funds as directed by the Organisers.
- 6.7.4 The clutch as supplied by Ginetta Cars Ltd must be retained in its original form.
- 6.7.5 Clutch master cylinder bore size 0.812 part number G40-G0053 may be fitted as an upgrade to the standard component.
- 6.7.6 Flywheel. The flywheel must remain as supplied by Ginetta Cars Ltd. The weight of any flywheel must be no less than 3.600kg and must not be modified in any way.
- 6.7.7 The Ginetta Cars Ltd supplied paddle shift system must remain as standard with no permitted modifications. The paddle-shift compressor location must be tunnel mounting as per the image **below**. Part number G50-G0211 Connection hose from compressor to receiver must be used.

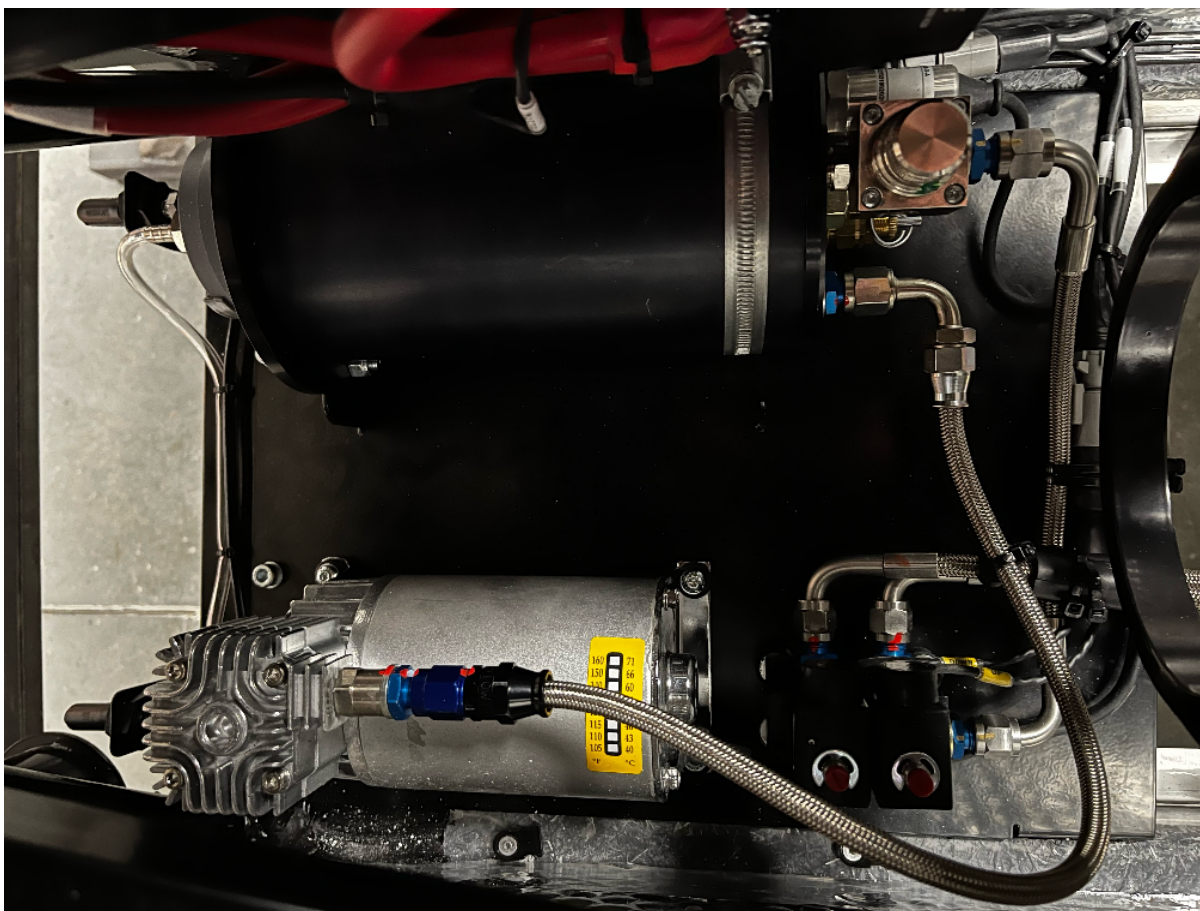

## 6.8 INDUCTION SYSTEM

6.8.1 The standard induction system as specified from time to time by and as supplied exclusively by Ginetta Cars Ltd and consisting of a single throttle body is the only permitted induction system. No modification to this system or inclusion of additional structures between the air box and throttle body assembly is permissible. The throttle body housing shall not be modified internally in any way. No polishing or re-profiling is permitted. The external throttle linkage including the throttle return spring and the fly by wire control unit may not be reworked or modified in any way. Air filter (G50-E0015) must be used supplied as standard by Ginetta Cars Ltd. No modification is permissible to this system whatsoever. If any component of the induction system is found ineligible then Championship Penalties under these Regulations including the Commercial Regulations will be applied by the Organisers.

## 6.9 ELECTRICS

6.9.1 Battery must remain as supplied by Ginetta Cars. The original location of the battery must be retained utilising the standard mountings. Terminals must be insulated. In compliance with Motorsport UK Regulation J 5.14.5 the battery earth lead should be identified by a yellow marking.

6.9.2 The coil on plug units must remain standard and in their original location. The dual-triple channel ignition modules must remain standard.

6.9.3 The fitting of additional instrumentation is not permitted unless under regulation **6.9.5**.

- 6.9.4 The standard Motec data acquisition system is the only permitted device and must remain set to standard configuration as supplied with the Ginetta GTA Car. No additional connections may be made to the ECU whatsoever.
- 6.9.5 As a routine part of eligibility control procedures it may be called upon by either the Championship Organisers or Licenced Eligibility Scrutineer to make available all acquired data from the above detailed equipment at any point for the purpose of collecting engine performance data during either race or qualifying sessions and during official test sessions / Ginetta organised sessions. For this purpose the ECU download point must remain in its standard location. No additional connections whatsoever shall be made to the ECU as and except as supplied by Ginetta Cars Ltd.
- 6.9.6 The Championship Organisers reserve the right to download and access all data at any time including but not exclusively during race or qualifying sessions and during official test sessions / Ginetta organised sessions. Entrants and competitors shall make the car including but not exclusively the ECU accessible to the Organisers forthwith on request for examination and if desired data capture.
- 6.9.7 Any competitor may be required by the Organisers to run additional sensors at any time. It is at the sole discretion of the Organisers acting through the Licenced Eligibility Scrutineer as to which cars must run any additional sensors.
- 6.9.8 The 12 volt standard alternator as specified from time to time by Ginetta Cars Ltd must be fitted. The minimum output of the alternator must remain as standard at all times. (Ginetta part number GIN-V6-N-0015)
- 6.9.9 The starter motor must remain standard as supplied by Ginetta Cars Ltd (Ginetta part number G50-E0004)
- 6.9.10 Cars must be fitted with model-standard Ginetta front lights with clear lenses or the alternative imitation light pod with clear lenses.
- 6.9.11 Cars must be fitted with the current Ginetta Cars Ltd specification rear lights including LED brake lights fog lights and indicators.
- 6.9.12 Steering angle logging kits may only be fitted using the approved Ginetta Cars Ltd upgrade kits and fitted as per supplied instructions.
- 6.9.13 The Motec Power Distribution Module and control panel key pad must be fitted, with the associated wiring loom, part number G123L-0049NA.00

## **6.10 COOLING SYSTEM**

- 6.10.1 The standard layout of the cooling system must be as issued by Ginetta cars LTD. The radiator (Ginetta part number G114P-0039NP.00) must be standard and remain in its original location.
- 6.10.2 The thermostat and housing must remain fitted and cannot be exchanged.
- 6.10.3 It is permitted to replace the standard radiator cap with a motorsport type radiator cap of the same fitting. Max pressure of the cap must not exceed 25psi. These must be the same specification as the component Ginetta Part Number G114P-0071NP.00
- 6.10.4 The diff cooler part number G50-N0014 must remain as standard and unmodified, along with the pump and associated pipework.
- 6.10.5 No other modifications than those referred to above are permissible.
- 6.10.6 Air conditioning systems must remain complete and in standard configuration, including all belts, pipework, pump and condenser. It is not a requirement for the system to be

gassed.

6.10.7 The standard braking system as supplied for the Championship exclusively by Ginetta Cars Ltd must be retained thus:

- **Front discs:**

Ferrous vented discs 330mm o/dia x 32mm thick Part no  
G50-I0027 (right-hand) and G50-I0025 (left-hand)

- **Rear discs:**

Ferrous vented discs 280mm o/dia x 32mm thick with 6 x grooves per side Part no –G50-I0026 (right-hand) and G50-I0027 (left-hand)

Minimum permitted disc thickness front and rear is 30mm. With:

- **Front Calipers:**

Alloy 4 pot calipers

Part No - G123I-0052RP.00 (right-hand), G123I-0051LP.00 (left-hand)

- **Rear Calipers:**

Alloy 2 pot calipers: with 2 x 41.3mm dia pistons and 2 x 38.1mm dia pistons Type:  
G123I-0057LP.00 (left-hand) and G123I-0058LP.00 (right-hand).

There are NO permitted modifications to the above.

Brake master cylinder pairs must be of the same make, model and size. The only permitted brake master cylinders are:

**Girling**

0.70" - G50-I0053

0.75" - G50-I0095

**Alcon**

0.70" - G109I-0057NP.00

0.75" - G109I-0059NP.00

6.10.8 All brake parts must be supplied exclusively through Ginetta Cars Ltd and must not be modified in any way.

6.10.9 Brake pads must be supplied by Ginetta Cars Ltd and are marked accordingly, and be part number G50-I0003 (Front) & G123I-0001NP (Rear). In the event of an eligibility dispute reference will be made to PERFORMANCE FRICTION who will decide if the disputed component is authentic.

6.10.10 Brake lines must remain as standard supplied by Ginetta Cars Ltd and in the manufacturer's layout.

6.10.11 Brake bias may be altered using the standard balance bar supplied by Ginetta Cars Ltd.

6.10.12 It is not permitted to direct air by means of ducting to the braking system unless previously advised in writing by Ginetta Cars Ltd as an approved system. The only exception to this will be the drilling of 3 x 50mm circular apertures in the brake master cylinder cover panel. These must be cut in front of the master cylinders only.

## 6.11 SUSPENSION

- 6.11.1 The standard suspension components and configuration as supplied by Ginetta Cars Ltd must remain unaltered except as specified below.
- 6.11.2 Front and Rear anti-roll bars must remain standard as supplied by Ginetta Cars Ltd and remain in the standard locations and standard material T45 35/2mm. Anti-roll bar stiffness adjustment is free within the range provided. It is permissible for one of the operating linkage rods to be removed.
- Front anti roll bar (Ginetta part number G50-C0115)
- Rear anti roll bar (Ginetta part number G50-D0039)
- In the event of a wet race, the rear anti-roll bar can be disconnected on all cars if necessary.
- 6.11.3 The minimum ride height measured from the centre line of the front wheel to the rear of the vehicle must be in excess of **70mm** for any part of the vehicle.
- 6.11.4 At each Championship round the Licenced Eligibility Scrutineer will designate a location where all ride height measurements shall take place.
- 6.11.5 These measurements shall be applied with the driver on board and with tyres normally inflated. If the ride height is measured at the end of an on-track session the tyre pressures may not be altered prior to the ride height being checked.
- 6.11.6 The front and rear wheel camber angle may be adjusted by means of standard size shims. The only permitted shims are those supplied by Ginetta Cars Ltd.
- 6.11.7 As standard the shims are supplied in the following thicknesses:
- 2.00mm
  - 3.00mm
  - 5.00mm
- 6.11.8 The front and rear wheel camber may be adjusted to a minimum by use of a single 2.00 mm thick shim per upright and to a maximum of 15.00 mm per upright using a combination of the standard shims.
- 6.11.9 The front and rear wheel toe in/out may be adjusted within standard limits and with no modification.
- 6.11.10 Springs. The only permitted springs are the ones as outlined below and supplied within the range as detailed by Ginetta Cars LTD and must be fitted to the front or rear of the car as described.
- 6.11.11 Spring rate and part numbers must be as follows:
- 550 lbs (Ginetta part number G123C-0041NA.00) Rear
  - 650 lbs (Ginetta part number G123C-0041NA.00) Front
- 6.11.12 If the distinguishing marks become illegible the component may be re-authenticated providing an audit trail and compliance with the component specification can be demonstrated.
- 6.11.13 Shock absorbers as specified as part number G123C-0001NP.00 (front) and G123C-0002NP.00 (rear) supplied exclusively by Ginetta Cars Ltd in either single or double adjustable format and must remain to the original specification as supplied and located as supplied by Ginetta Cars Ltd. Damper traces detailing the required specification can be

supplied by Ginetta Cars Ltd.

6.11.14 The standard track and wheelbase dimensions must be retained.

6.11.15 Wishbones must remain in standard specification and only be fitted with approved associated spacers.

6.11.16 Toe link must remain standard with no modification.

## **6.12 WHEELS**

6.12.1 The standard wheels of size 18" x 9" as supplied by Ginetta Cars Ltd (Ginetta part number G50-J0001) must be used on the all axle uprights and may not be modified or substituted for others.

6.12.2 The use of wheel spacers or other wheel spacing mechanism is not permissible.

## **6.13 TYRES**

6.13.1 Tyre Allocation Plan:

<b>ROUNDS</b>	<b>VENUE</b>	<b>DATES</b>	<b>TYRE ALLOCATION</b>
1,2,3	Oulton Park	30/01 April	6 NEW
4,5	Silverstone	27/28 April	4 NEW 2 USED
6,7,8	Donington Park	25/26 May	4 NEW 2 USED
9,10,11,12	Anglesey	29/30 June	6 NEW 2 USED
13,14,15	Snetterton	13/14 July	4 NEW 2 USED
16,17,18	Donington Park	07/08 September	4 NEW 2 USED
19,20,21	Brands Hatch	28/29 September	4 NEW 2 USED

6.13.2 The intention of these regulations is:

- To contain costs by limiting the number of tyres which can be purchased on behalf of any one driver during the series.
- To limit the number of tyres used per car/driver per complete event.
- To prohibit the use of any method of raising the temperature of tyres by adding heat artificially.
- To prohibit the application of any material to alter the standard performance of the tyres.
- Any attempt whatsoever to circumvent these intentions or any fraudulent attempt to deface re-mark counterfeit or otherwise circumvent the unique tyre numbering system will automatically be the subject of a report to the Clerk of the Course and / or Championship Stewards for the application of penalties under these Regulations including revocation of all relevant Registrations.

6.13.3 The only permitted dry tyres for use in this Championship is as follows: Pirelli 245/40ZR18XLTL (97Y)

6.13.4 The maximum number of tyres available to each car for use during the Championship

season will be limited to 32 for all cars in accordance with the Tyre Nomination Plan above **6.13.1**. These tyres must be used in all official Qualifying sessions and races, and must be nominated during the season as described in **6.14**.

- 6.13.5 The only permitted wet tyres for use in this Championship are Pirelli 245/645-18AOF10v01 RAINWH. These tyres do not have to be included as part of the 6 tyres that are presented at scrutineering. These tyres must be supplied by Ginetta Cars Ltd or their designated tyre supplier Prot tyre Motorsport. The number of wet specification tyres for use in the GTA car in the Ginetta GT Academy is not restricted.
- 6.13.6 It shall be the sole responsibility of the Drivers/Entrants to judge whether the track is wet enough to justify the use of wet weather tyres.
- 6.13.7 The Clerk of the Course will not judge whether the track is wet enough to justify the use of wet weather tyres.
- 6.13.8 Wet tyres may not be used in conjunction with dry tyres.
- 6.13.9 The 6 tyres allocated for use at the first event of the season must be “brand new”, (A tyre can be deemed to be brand new if it has not had any use on a vehicle) when the car is presented for Scrutineering prior to the first on track session on the Saturday at the start of the event. These tyres must be purchased from the designated tyre supplier on the same weekend they are due to be used. It is the competitor’s responsibility to ensure the designated tyre supplier receives a set of rims in good time, to allow the tyres to be fitted prior to the tyres being released at the start of the event.
- 6.13.10 The six new tyres used at round one will be suitably marked and logged and the four brand new and two carry over used tyres for subsequent rounds must then be presented on the car for use at the following event. All tyres must be logged via the Tyre Nomination Form which can be found on; <https://hub.ginetta.com/>
- 6.13.11 In the occurrence that any damage to the race set of tyres makes participation impossible, it will be allowed to substitute in brand new tyres. Substitute tyres may only be fitted with the express permission of the Licenced Eligibility Scrutineer in consultation with the Championship Coordinator who will need to be notified when the tyres are fitted, regardless of when this occurs the only reason a competitor may utilise a spare tyre is through damage to one of the four nominated tyres.
- 6.13.12 Once fitted, the replacement tyre must then be used as part of the race set for the remainder of the meeting and any following meeting they are required as detailed in **6.13.1**.
- 6.13.13 During qualifying and races, it is permissible to have available in the pit-lane, the other two nominated tyres to be changed in the event of damage occurring during the sessions. These are the only tyres that will be allowed in the pit-lane.
- 6.13.14 If a competitor joins the Championship part way through the season or for a single round, they can nominate 6 brand new tyres from their first round and then following the tyre allocation plan as listed in **6.13.1**.
- 6.13.15 Bar-coding and / or permanent paint marking will be used to control tyre use. It is the competitor’s responsibility to ensure that all tyres are marked before use and logged by the series coordinator and/or Licenced Eligibility Scrutineer.
- 6.13.16 All tyres must be supplied by Ginetta Cars Ltd or their designated tyre supplier Prot tyre Motorsport. Tyres will be marked accordingly to certify that they have been supplied by one of these sources.
- 6.13.17 Tyre location on the GTA Car must remain standard throughout any qualifying session i.e.

it is not permissible to move tyre location across an axle or front to back mid- session.

- 6.13.18 If a tyre is damaged during a qualifying track session it may only be replaced with permission from the Licenced Eligibility Scrutineer and who may in his absolute discretion for the purposes of this Regulation consult with the tyre manufacturer or manufacturer's agent.
- 6.13.19 Tyres must have a tread depth of at least 2mm across the full width of the tyre prior to the start of any on track session.
- 6.13.20 The use of tyre heating equipment / heat retention devices tyre treatments or compounds is prohibited. Any artificial cooling of tyres is prohibited.
- 6.13.21 The Organisers reserve the right to amend the tyre allocation during the course of the season, which will be communicated to competitors by way of a Championship bulletin.
- 6.13.22 It is only permitted to inflate tyres with air of atmospheric composition no other medium may be used. The Licenced Eligibility Scrutineer may request for the inflated tyres to be tested at any time to ensure that no medium other than air is being used.
- 6.13.23 Only in exceptional cases where in the judgement of the Licenced Eligibility Scrutineer damage to a maximum of 2 (two) nominated tyres makes further participation in the event impossible nominated 'used' front and/or rear tyres may be substituted. A 'used' tyre is defined as a tyre that has been nominated at a previous race meeting and has been recorded as such by the Licenced Eligibility Scrutineer. The substitution may only be authorised by the Licenced Eligibility Scrutineer.
- 6.13.24 The only exception to this is the first race weekend of the year. If during the first race weekend of the year damage to a maximum of 2 (two) nominated tyres makes further participation in the event impossible two new tyres may be substituted. The substitution may only be authorised by the Licenced Eligibility Scrutineer
- 6.13.25 In very exceptional cases where in the judgement of the Series Licenced Eligibility Scrutineer damage to tyres through no fault of the competitor makes further participation in the event impossible and all previously nominated tyres are not usable additional tyres above the total allocation for the season may be purchased. However, for every additional tyre purchased the competitor will incur a nine (9) Championship point deduction. It is the competitor's responsibility to notify the Licenced Eligibility Scrutineer of their intention to exceed the tyre allocation prior to any Qualifying sessions or races.
- 6.13.26 It is not permitted to use any means to artificially raise the temperature of tyres above ambient at any time prior to or during any event other than by the natural addition of heat resulting from permitted driving on the circuit.
- 6.13.27 Tyre warmers or any other device intended to modify or maintain tyre temperature is forbidden. Tyre warmers found at the circuit will be judged to be available for use and appropriate action will be taken.
- 6.13.28 Tyres must only be used in the standard condition as supplied by the manufacturer. The application of any material (liquid solid or gas) to any part(s) of the tyre is therefore forbidden. The only exceptions are the use of a mixture of pure domestic water and household detergent, or the lubricant applied to the tyre bead for fitting purposes. The Championship Organisers reserve the right to take samples of tyre material at any time for laboratory analysis.
- 6.13.29 The application of any material (liquid solid or gas) to any part(s) of the tyres during official practice is forbidden.
- 6.13.30 It is not permitted to remove debris / rubber pick-up from the tyre surface by the use of



a tool and / or heat gun.

6.13.31 Any tyre protection covers used at any time within the confines of the circuit must be of a temporary construction and must be capable of being used many times.

6.13.32 Pressure regulation valves are forbidden.

#### **6.14 TYRE NOMINATION**

6.14.1 Each competitor must record on the Tyre Nomination Form the serial numbers of the 6 dry tyres which they intend to use in the event.

6.14.2 The Form must be submitted online via Ginetta's nominated form to the Licenced Eligibility Scrutineer before the first timed practice. The onus is on the competitor to ensure that the completed form is deposited with the Licenced Eligibility Scrutineer and appointed representative before the first official timed practice. Failure to do so will be the subject of a report to the Clerk of the Course / Stewards.

6.14.3 During qualifying and races only, tyres nominated under **6.13.1** and wet weather (treaded) tyres may be kept in the pits.

6.14.4 During the event checks will be made by the Licenced Eligibility Scrutineer or their appointed representative to ensure compliance between the tyres used and serial numbers recorded on the nomination form. At the end of the race all placed cars may be checked for compliance with this tyre regulation. Non-compliance at any time during the event will be the subject of a report to the Clerk of the Course/Stewards.

6.14.5 At the Licenced Eligibility Scrutineer's discretion the 6 tyres for the event listed on the Tyre Nomination Form may be retained at the end of Official Qualifying and Race(s) until a minimum of 30 minutes prior to next time that the tyres are required to be used.

#### **6.15 WEIGHT**

6.15.1 The minimum vehicle weight excluding driver is 1230kg including driver is 1325kg. The latter weight is intended to include the driver suitably dressed for competition with safety helmet and all safety equipment. It is emphasised that both these minimum weights must be respected at all times during both Qualifying and Competition. Failure to meet either or both will be considered an offence under these regulations.

6.15.2 Guest Competitors in the GTA class must run an additional 25kg above the minimum weights as described in **6.15.1**. This will not apply to Guest Competitors in the Rookie class.

6.15.3 In order to meet the criteria of **6.15.1** only it is permitted to add ballast to the car in accordance with Motorsport UK General Regulations J 15.15.1 – J15.15.4 Such ballast must be formed of solid unitary blocks. They must only be fixed using a ballast plate supplied by Ginetta Cars Ltd (Part number G123R-0051NA.00) which is bolted to the floor of the passenger seat well in the designated area of the car. The ballast plate fixings must be able to withstand acceleration / deceleration forces of 25G.

6.15.4 Provision must be made for the Licenced Eligibility Scrutineer to affix seals to any ballast fitted.

6.15.5 Following competition, the driver must remain available with the car under Parc Fermé conditions until released by the Licenced Eligibility Scrutineer and / or Organisers in order to ensure weighing is completed with the minimum of delay. Drivers who are required for post-race prize giving and / or media interviews and who are directed from Parc Fermé by an official of the meeting or a Ginetta official are permitted to leave Parc Fermé although must return to their car after such events have taken place to ensure weighing is

completed.

- 6.15.6 If a car loses a part during qualifying or a race the weight of that part may be taken into account during eligibility checks. Following consultation, the Licenced Eligibility Scrutineer will determine whether any lost part should be taken into account.
- 6.15.7 The Organisers reserve the right to amend the minimum weights. Any amendments will be made by official Championship bulletin.

#### **6.16 FUEL, FUEL INJECTION AND FUEL TANK**

- 6.16.1 A standard fuel tank as supplied by Ginetta Cars Ltd must be retained in its original position. The fuel delivery system must remain as original specification.
- 6.16.2 The standard 60 litre fuel tank and fuel delivery system may only be substituted by alternative components that are approved and supplied by Ginetta Cars Ltd. If alternative components are to be used these must be declared within the car's log book when the car is presented for scrutineering.
- 6.16.3 The Championship official fuel supplier is mandatory. Compliance with this regulation will be verified by fuel testing throughout the season. Details of the official Championship fuel supplier will be provided at the start of the season by Championship Bulletin.
- 6.16.4 At the end of practice / qualifying and of the race at least 3 litres of fuel from the tank of the competing car must be available to the Licenced Eligibility Scrutineer for analysis if required. Compliance with minimum weight for the car will be taken before fuel is removed as part of any eligibility check.
- 6.16.5 Front bulkhead to fuel rail upgraded fitting Ginetta Cars Ltd part number G50-M0027 must be fitted to a 3.7 V6 and G123M-0027NP.00 & GIN-LMP3-M0084 must be fitted to a 3.5 V6 rather than the original jubilee clip.

#### **6.17 SILENCING**

- 6.17.1 The exhaust system as supplied by Ginetta Cars Ltd must remain as standard and may not be altered. All cars must comply with Motorsport UK General Regulation J5.17. concerning noise levels and it is the competitor's responsibility to ensure that the car complies with currently enforced levels.

#### **6.18 PRESENTATION**

- 6.18.1 Having due regard to the best interests of the Championship Sponsors the Championship image Ginetta Cars Ltd and of safety competing cars are to be presented in a clean and mechanically and visually acceptable condition. Organisers reserve the right to insist that such standards of presentation are maintained as a condition of racing within the Ginetta GT Academy Championship. Individual cars may fail scrutineering if as deemed by the Licenced Eligibility Scrutineer to be of poor presentation and / or mechanically unacceptable.

## **7. ROOKIE CLASS ADDITIONAL REGULATIONS**

### **7.1 GTA ROOKIE**

7.1.1 The following Rookie Class Regulations are intended for drivers entering the Rookie Class only, and will carry the same penalty as any breaches of the main technical regulations.

### **7.2 CAR SET-UP**

7.2.1 Rookie Class cars will be required to have the following vehicle set-up applied during all on-track sessions:

- Roll-bar: One from full stiff front, two from full stiff rear.
- Camber shims: 5mm all round.
- Rear wing: hole B1, bracket hole A1.

7.2.2 The rear anti-roll bar can be disconnected on all cars if necessary.

### **7.3 WEIGHT**

7.3.1 The minimum vehicle weight excluding driver is 1230kg including driver is 1325kg. The latter weight is intended to include the driver suitably dressed for competition with safety helmet and all safety equipment. It is emphasised that both these minimum weights must be respected at all times during both Qualifying and Competition. Failure to meet either or both will be considered an offence under these regulations.

## **8. COMMERCIAL REGULATIONS**

**8.1** The following Commercial Regulations are contractual between the Entrant and / or Teams and / or Driver and the Organisers and / or Promoters and are not considered by Motorsport UK. Accordingly, the application of these Commercial Regulations by the Organisers and / or Promoters will not be subject to the Judicial processes of either the Championship Stewards and / or the Motorsport UK / MSC. However, these Commercial Regulations are in the nature of a continuing binding contractual warranty and Regulations given by and on behalf of all Entrants Teams and Competitors in the Championship to the Organisers by the action of applying for and during any current period of Registration and accordingly they are enforceable as such.

**8.2** All Entrants Teams and Competitors acknowledge warrant and undertake with the Organisers that any Championship Registration under these Championship Regulations may be suspended withdrawn or revoked by the Organisers for any breach of these Championship Regulations including but not exclusively these Commercial Regulations. Such suspension withdrawal or revocation of Registration except as provided herein shall not serve in the nature of any liquidated damages or penalty for breach of the contract that is represented by the Championship Regulations and the Organisers are at liberty to seek such remedy and in such forum as they may in their absolute discretion deem appropriate.

### **8.3 COMMERCIAL REGULATIONS**

**8.3.1** The Race Meetings comprising the Championship shall be conducted in accordance with the Regulations and these Commercial Regulations.

**8.3.2** The Organisers acting through the Championship Coordinator have the right to amend vary or add to the Commercial Regulations from time to time. Such amendments variations and additions shall be notified by bulletin to all Championship Registrants by posting to the address detailed on the Championship Registration Form or sending to the e-mail address detailed on the Championship Registration Form or faxing to the fax number detailed on the Championship Registration Form or delivery to the competitor by hand.

**8.3.3** All Competitors Entrants Teams and persons associated with them for the purposes of the Championship agree to be bound by the Commercial Regulations and any additions variations or amendments thereto and Competitors Entrants Teams shall procure compliance by persons associated with them.

**8.3.4** All the prizes stated in regulations **1.8** will only be issued to Competitors whose accounts with Ginetta Cars Ltd are up to date as at close of business on 30 November following the race season. Any Competitor whose accounts are not up to date as at close of business on 30 November following the race season relinquishes all rights to prizes.

### **8.4 PENALTIES**

**8.4.1** WARNING: The terms of the Commercial Regulations are fundamental to the contract between Organisers and the Registrants respectively. All Entrants Teams and Competitors acknowledge warrant and undertake with the Organisers that any breach of these Championship Regulations including any breach of any of the Commercial Regulations may render the Registrants and any of them ineligible for competition and in such circumstances continued participation in the Championship will be entirely at the discretion of the Organisers who may revoke suspend or withdraw any Registrant. The Organisers as an alternative and/or in addition to revoking suspending or withdrawing the Registration of the Competitor and / or Entrant and / or the Team for participation in the

Championship may but subject to their absolute discretion refer the matter to the Championship Stewards in order that if those Stewards see fit they may impose any one or more of the following penalties as a condition of continued participation in the Championship but in respect of such matter there shall be no contractual right of appeal:

- Reprimand which may include forfeiture of a qualifying time or times
- Time penalty
- Disqualification
- Forfeiture of Championship points (even if this results in a minus total of points)

8.4.2 In addition, or in lieu of any such penalty, the Organisers acting through the Championship Coordinator may require the competitor and/or team to take such steps as may be reasonable to mitigate the damage to the reputation of the Championship and / or the Organisers or any of them.

8.4.3 In the case of an alleged breach of any Commercial Regulation the decision of the Organisers is final as to the culpability and penalty (and for the avoidance of doubt there is no appeal to the MSC National Court).

8.4.4 A breach of any of the Commercial Regulations may additionally or alternatively result in a fine as contractual liquidated damages up to a maximum of £1000 for each offence being imposed by the Organisers acting through the Championship Coordinator. All such liquidated damages must and shall be paid forthwith as a debt to Ginetta cars Ltd and Championship Registration will be suspended until such payment has been received.

8.4.5 Where in the opinion of the Organisers any Competitor(s) and / or Entrant and / or Team has gained an unfair advantage (whether inadvertently or not) from a breach of the Commercial Regulations by its own actions or those of another Competitor or Team the Organisers acting through the Championship Coordinator may impose any one or more of the penalties set out in Commercial Undertaking **8.4** above in order to remove or otherwise compensate for such advantage.

8.4.6 All cars must have a transponder fitted and working for any official practice session prior to race weekends. All Friday practice sessions immediately prior to race weekends are classed as official practice sessions. Any competitor running without a transponder during an official test session will have Championship points deducted. 5 Championship points will be deducted for each test session that a driver fails to fit a working transponder.

8.4.7 It will be at the decision of the Organisers and / or Clerk of the Course as to whether or not a driver is penalised. Any evidence may be used to determine whether or not a working transponder has been fitted including information / data from the official timekeepers.

## **8.5 FRANCHISE AGREEMENT**

### **Ginetta Team Franchise Details**

8.5.1 In order for teams to run cars in Ginetta Championships they will be required to sign up to a Ginetta Team Franchise agreement. This will ensure that the customer proposition can be more consistent and allows teams to have a more confident future within the Ginetta franchise because drivers will be required to run with those teams who have a franchise agreement with Ginetta.

8.5.2 Teams are invited to apply for Franchised status - there is no minimum number of cars a team can run in any one Championship, but they will be limited to 6 cars per Championship. If a team signs the franchise agreement, then they will appear on the

Ginetta website/social media as an approved race team and have the right to have cars entered in any of the three Ginetta championships.

8.5.3 Ginetta will seek to control the number of teams who are signed up to the franchise in order to ensure teams generate a strong income from the championships in return for their commitment.

8.5.4 Franchised teams will be required to conform to the following requirements:

- Have a Valid MSUK Entrants licence
- Pay entry fees at the prevailing rate
- Attend all mandatory Ginetta exclusive test days (*1 per weekend*)
- Run a maximum of 6 cars per category
- Conform to a set level of presentation for paddock presence
- Conform to a set level of presentation for all cars
- Only use Ginetta approved driver coaches to be approved at the start of the season with any changes mid season to be agreed in advance.
- A Franchise can be removed at any time.

8.5.5 As well as the above, we will require all of the following information prior to the start of the season, by 31st January 2024.

- All H&S Documents:
  - Risk Assessment and Method Statement
  - Public Liability insurance
- A signed copy of the front and back of the Motorsport UK Entrants Licence
- All relevant signed and completed Championship documents
  - Entry Form
  - Parent/Guardian Form (*Under 18s*)
  - Commentary Form
- WhatsApp Group Form
- A fixed fully working transponder for every car, with the numbers submitted prior to the deadline.

Championship entries can only be placed by Franchised teams, not drivers directly.

All teams have to re-apply for 2024 and new teams can register their interest for a Franchise by emailing Kelly Edmund.

## **8.6 ADVERTISING**

8.6.1 No advertising of tobacco or tobacco products is permitted in any shape or form in this Championship. Additionally, any products that are not permitted to be advertised on UK television are also prohibited. The Organisers reserve the right to censor any advertising that may at the absolute discretion of the Championship Coordinator and / or the Organisers be deemed to be unsuitable. Any car or driver considered by the Championship Coordinator and / or the Organisers in their absolute discretion to be exhibiting unsuitable advertising may be disqualified from any Round of the Championship.

## **8.7 PUBLICITY**

- 8.7.1 At all Championship Meetings Drivers wearing their driving overalls must take part in any autograph session paddock walkabout and pre-race parade when requested by the Coordinator.
- 8.7.2 All drivers who qualify for an award pursuant to Commercial Regulation 6.15 shall attend the podium ceremony and any post-race televised interviews wearing their race winners caps to be provided by Ginetta Cars Ltd. Failure to attend the podium ceremony or failure to attend correctly attired may result in a fine being imposed by the Coordinator.
- 8.7.3 In signing the Championship Registration Form Competitors Entrants and Teams agree that the Organisers may make use of his/her/its activities and successes in motor sport for any advertising publicity public relations and merchandising purposes. The Competitors Entrants and Teams also agree that in any advertising or promotion with which they are associated (relating to the Championship) the full title of the Championship (including the Championship sponsors name) will be used at all times.

## **8.8 TELEVISION**

- 8.8.1 By entering the Championship competitors, entrants and teams are obliged to assist the Organisers in the promotion of the Championship and in particular any television coverage that may arise during the term of the Championship.
- 8.8.2 All competitors' entrants and teams are obliged to assist any nominated Championship TV production company in the filming of Championship events and related activities through the granting of interviews when requested and any other reasonable requests of the TV production company or the Organisers.
- 8.8.3 Drivers finishing first second and third in the Drivers' Championship must make themselves available immediately after each Qualifying session Race and/or the prize giving ceremony for any media interviews in accordance with the requirements and directions of the Organisers.
- 8.8.4 At the request of the Organisers all cars must carry an in-car camera or on-board camera during testing free practice official qualifying sessions and/or the races at the request of the TV production company and if requested by the Organisers all cars must carry a Championship on-board Judicial camera.
- 8.8.5 Footage from any camera used by competitors or teams cannot be used for commercial exploitation or public broadcast. Any footage produced in breach of this Regulation will forthwith upon request be delivered up to the Organisers in addition to any penalty imposed.
- 8.8.6 Any competitor and/or anyone connected with a competitor is prohibited from trying to influence the editorial decisions of any TV production company in connection with the Championship as it is shown on television or of otherwise interfering with television coverage.
- 8.8.7 The decision as to which car is to carry an on-board camera and/or an in-car camera rests solely with the Organisers whose decision shall be final.
- 8.8.8 It is permitted to install own brackets in a competing car in order to incorporate an in-car camera but always subject to the prior approval of the Licenced Eligibility Scrutineer and the nominated TV production company.
- 8.8.9 The Organisers nominated TV production company shall have unrestricted access to any moving image footage captured by the drivers and / or teams or their associates and may

incorporate any such material in its coverage of the Championship.

- 8.8.10 All footage obtained or recorded by the Organisers' Nominated TV production company of the Championship belongs to the Organisers and/or the Organisers nominated TV production company and all competitors, entrants and teams and their associates consent to their images being used by the Organisers (and those authorised by it) for promoting the Championship and if applicable any merchandise associated with the Championship.

## **8.9 MERCHANDISING**

- 8.9.1 The Competitor Entrant and Team hereby authorise the Organisers to use and reuse and sublicense the use of images and representations of the vehicles competing in the Championship and the name images and representations of the driver the Team the Team logo and Team paraphernalia including (insofar as the same appear on the clothing worn by the competitor or on Team paraphernalia or on the cars driven by the Competitor in the Championship) the logo and decals of all sponsors of the Competitor and/or Entrant and / or Team for the purposes of producing merchandise exploiting the reputation of the Championship and all elements of the Championship.
- 8.9.2 The Competitor Entrant and Team authorise the Organisers to use and licence others to use all Championship images and other material relating to the Championship in marketing and packaging material and commercial advertisements exploiting the Championship or merchandise of the Championship or any individual elements of the Championship.
- 8.9.3 The Competitor Entrant and Team shall assist the Organisers and those authorised by it with the promotion of the Championship and production and promotion of merchandise associated with the Championship.

## **8.10 MEETING ARRANGEMENTS**

- 8.10.1 Throughout the course of the Championship the Championship Coordinator on behalf of the Organisers may inspect all race transporters and motorhomes to ensure that they are of smart appearance and in good order. The Championship Coordinator may refuse to issue a Paddock vehicle pass to any vehicle that is deemed by the Organisers to be unsuitable for display within the Paddock.
- 8.10.2 At the start of each Meeting practice session and race the competing cars and all Team vehicles must be clean of smart appearance and in good order. The Championship Coordinator and Organisers reserve the right to suspend competitors not meeting this requirement from taking further part in the Championship and withdraw passes until this Regulation is fulfilled to their satisfaction.
- 8.10.3 Any team considered by the Organisers in their absolute discretion to be exhibiting unsuitable advertising may be asked to and shall thereby withdraw it immediately.
- 8.10.4 Any pipes wires or cables trailing from motorhomes and/or transporters and/or generators must be protected by hard covers where they will be crossed by vehicles or pedestrians. All health and safety requirements must be met at all times and warning signs must be erected where there is any danger to the public or other persons.

## **8.11 SRO PASSES**

- 8.11.1 Permanent passes will be issued to each registered Ginetta Junior competitor for his/her sole use and these will be valid for every round of the Championship. Each competitor shall be given the following number of passes:
- 6 x Pit Lane/Paddock Access Passes



- 2 x Private car passes
  - 1 x Transporter Pass
- 8.11.2 Please note that these passes are issued in accordance with Commercial Undertaking **9.2** with respect to Team transport.
- 8.11.3 SRO passes will be issued to each registered Entrant/Driver for their sole use and these will be valid for every round of the Championship. Entrants/Drivers shall make applications for passes by completing the Vehicle/Staff Information Form and returning it to the Championship Co-ordinator by 1<sup>st</sup> March. The Championship Co-ordinator will not process Vehicle/Staff Information Sheets unless they are fully complete. Submission of an incomplete form or late return of the form to the Championship Co-ordinator, may result in no passes being available for the first Event and the withholding of an Entrant's/Driver's entry.
- 8.11.4 SRO passes are issued on condition that the person or organisation to whom they are issued waives any and all claims it may have now or in the future and releases from all liabilities and agrees not to take any legal action and to always hold harmless, SRO Motorsports Group, BRSCC Ltd and their employees, agents and representatives and servants, the Motorsport UK, the Race Organisers, the Promoters, the Venue Owner, the Championship Coordinator, any participating Team and all employees, agents, servants and contractors thereof for any personal injury, death, damage or loss of any kind that the pass holder may sustain as a result of or in connection with the pass holder's presence within the venue. This indemnity does not apply insofar as injury or death is caused as a result of the negligence of the party seeking an indemnity.
- 8.11.5 Entrants/Drivers will be required to sign for receipt of their SRO passes. By accepting the issue of these passes, the Entrant/Driver is deemed to agree to abide by the pass conditions and to undertake the obligation to advise each person to whom they are issued of the pass conditions and to ensure the observance thereof.
- 8.11.6 SRO passes are issued subject to the following conditions:
- A SRO pass may only be used to gain access to the areas indicated on the face of the pass. Any person found within a restricted area without the appropriate pass may be removed from the venue immediately and/or have any pass held by them withdrawn.
  - A SRO pass may only be used by the Entrant/Driver to whom it is specifically issued. It is forbidden to alter or deface passes in any way or to allow a pass to be used to authorise the entry of more than one person at each Event,
  - SRO passes must be worn around the neck of the person to whom it is issued so as to remain clearly visible at all times. It is forbidden to combine with or enclose a SRO pass within a wallet or holder of any kind (unless supplied by SRO or the Championship Organisers) or to attach additional items of any kind to it,
  - SRO reserves the right to request further proof of identity in addition to a SRO pass,
  - SRO at all times reserves the right to refuse admission to the venue or access to a designated area to any person, notwithstanding that such person may have been issued with an appropriate SRO pass.
- 8.11.7 SRO, in conjunction with the Championship Coordinator, reserves the right to remove immediately from the venue any person who is found to have violated the pass conditions contained in these Commercial Undertakings and/or to withdraw permanently a SRO pass issued to such person and/or to take or institute legal proceedings against that person.
- 8.11.8 All registered Entrants/Drivers are fully liable for any personnel and vehicle passes issued

to them by SRO and/or received on the Entrant's/Driver's behalf. The misuse of any passes allocated to an Entrant/Driver will result (without prejudice to any other action which may be taken by SRO under the terms of these Commercial Undertakings) in SRO and or Ginetta Cars Ltd imposing a fine of £1,000 for each act of misuse of the pass together with the confiscation of the pass concerned for such period of time as the Coordinator shall deem appropriate.

- 8.11.9 If a Championship Registration is withdrawn/forfeited, all passes issued in connection with that Registration must be returned to the Championship Coordinator. Any lost/mislaid passes will be subject to a penalty of £25.00 per pass multiplied by the number of remaining rounds.
- 8.11.10 SRO passes will not be replaced if they are lost/mislaid unless they have been stolen and a copy of the police report relating to that offence is submitted to the Championship Coordinator.
- 8.11.11 Each Entrant/Driver must also attend this Ginetta Media Day with their intended Paddock vehicle for the season and erect their awning (if applicable) for measurement by the Paddock Team. Passes will not be issued until the plot size has been measured and agreed.

## **8.12 PADDOCK REGULATIONS**

- 8.12.1 The amount of space requested will not necessarily be the space granted to an Entrant by the organisers who will assess individual requirements at the Ginetta Media Day.
- 8.12.2 Each team will be permitted one transporter and awning to be parked in their designated Paddock area. Any Entrant requiring an additional awning must make a request in writing to the Championship Coordinator prior to the first Event. Only Entrants running more than four cars will be permitted an additional awning. Entrants running three or more cars may be permitted additional space for a Support Vehicle/flat patch. Awnings are not permitted on Support Vehicles. Please refer to Regulation **3.20.5** regarding the mandatory provision of fire extinguishers.
- 8.12.3 No hospitality/entertaining will be allowed by Entrants/Drivers within the Paddock. Teams may use an area at the rear of their awning specifically for team catering only.
- 8.12.4 Motorhomes/caravans and private cars are not permitted within the Paddock at any venue unless in exceptional circumstances and with the prior written approval of the Coordinator.
- 8.12.5 There is a speed limit of 10mph in the Paddock at each venue. The only movement of race cars permitted in the Paddock is on the way to the Assembly Area and on the way back from Parc Fermé with a current full road traffic licence holder seated in the Driver's position and in control of the car.
- 8.12.6 Tailgates on transporters must remain closed at all times except when loading and/or unloading your race cars.
- 8.12.7 Hard covers should protect any pipes wires or cables trailing from motorhomes transporters and/or generators where they will be crossed by pedestrians and/or vehicles.
- 8.12.8 All health and safety regulations as well as any such directives issued by the Championship and/or the venue must be met at all times.
- 8.12.9 It is an offence for any person to ride or drive any motor vehicle on the roads or other public areas under the control of the venue promoters unless they are covered by third party insurance. It is a condition of Registration that such insurance is in place. A copy of the policy must be lodged with the Championship Coordinator before the first Event of the season.

- 8.12.10 The competitor's Entry Fee does not cover the provision of generator power for the paddock and to private motorhomes caravans or suchlike during an event.
- 8.12.11 ALL golf buggies or pit vehicles are to be parked either alongside or behind awnings or within the confines of your allocated space in the paddock. No golf buggies or pit vehicles are to be parked in the roadway.
- 8.12.12 All Paddock vehicles that require personnel to be on the roof (i.e. to affix awnings or flag poles/flags) must have the relevant safety equipment fitted. Any personnel on the roof must wear the relevant safety harnesses which must be affixed to the equipment on the roof, a £500 fine can be incurred if not adhered to. Please note that there will be regular H&S checks during the course of the season.

### **8.13 TIMETABLE REGULATIONS**

- 8.13.1 SRO Motorsports Group (and those authorised by it) reserves the right to amend the race day timetable at its discretion.
- 8.13.2 Entrants/Drivers should listen carefully to the Paddock tannoy announcements and their Championship Coordinator regarding the time they are required in the Assembly Area. In ideal conditions the timetable may be brought forward and Entrants/Drivers may be called to the Assembly Area earlier than originally scheduled. Entrants/Drivers are warned that they will miss their qualifying session or race if they are not ready in the Assembly Area when the cars are released.

### **8.14 RADIOS**

- 8.14.1 At any point during the season the Organisers may introduce a mandatory Race Control to Driver Radio. Upon such introduction, Art. 8.14.2 – 8.14.4 will apply.
- 8.14.2 For all official sessions, including any Free Practice, Qualifying and Races, all competitors must use the mandatory 'Race Control to Car' radio receiver for which the transmitter shall be under the sole control of the Clerk of the Course and used to communicate instructions or warnings to the drivers from Race Control. See Motorsport UK General Regulation Q11.3(a).
- 8.14.3 Should a competitor not have a working receiver fitted during an official session or fail to comply with any message or instruction(s) from the Clerk of the Course, they may receive a penalty. The responsibility remains with the competitor to ensure their receiver is in full working order during all official sessions.
- 8.14.4 The mandatory receiver may only be purchased directly from the BRSCC.
- 8.14.5 It is not permitted to use any form of personal pit to car communication systems during Qualifying and races at any event. Systems will be permitted during Friday free practice and Ginetta exclusive test days but all equipment must be removed for Qualifying and races.
- 8.14.6 Radio frequencies used by an Entrant/Driver team member and/or any of their suppliers must be licensed for use in the UK by the appropriate regional office of the Radio communications Agency.
- 8.14.7 The Entrant/Driver team member and/or any of their suppliers must at all times comply with the terms and conditions specified from time to time by the Radio communications Agency for the use of their radio frequency.
- 8.14.8 In the event that a frequency used by an Entrant/Driver team member and/or any of their suppliers interferes with a frequency used by a local emergency service or other third

party the Entrant/Driver team member and/or supplier shall forthwith change its radio frequency to a non-conflicting frequency. The Entrant/Driver team member and/or any of their suppliers will be suspended from qualifying and racing until a change of frequency has been affected.

8.14.9 If an Entrant/Driver team member and/or any of their suppliers wish to change their frequency they must first obtain approval from the Radio communications Agency.

8.14.10 It is not permitted to scramble radio speech transmissions or encode them in any way

## **8.15 MISCELLANEOUS**

8.15.1 Competitors entrants and teams and officials may not either individually or with any such participants or through any representative or agent procure solicit or arrange for any supplies gratuities products merchandise equipment or any other thing of value to be provided from any source whatsoever bearing or depicting any Championship logo and/or any trademark and/or any copyright and/or any image used or associated with the Championship without the prior written permission of the Coordinator to do so.

8.15.2 All images photographs recordings or representations of the participation in the Championship or association with the Championship of competitors entrants and teams may only be used for commercial purposes with the prior written consent of the Coordinator. No consent is required for normal media reporting of the Championship.

8.15.3 All the broadcast recording cable satellite digital video internet and interactive rights and other rights in all media to the Championship and other related events are the sole property of SRO Motorsports Group, Hayfisher Productions and/or Ginetta Cars. Any recording or broadcast of the Championship and other related events or rebroadcast or reproduction of material without express written permission of the Coordinator is strictly prohibited. Competitors entrants and teams currently registered in the Championship may subject to the prior written permission of the Coordinator and subject to any conditions that he may impose at his/her absolute discretion be granted rights to use broadcast material for their own specific promotional use within the UK without fee or charge. Rights requested for any other commercial use must be made in writing to the Coordinator and if granted will be subject to Licence which may include a fee or charge.

8.15.4 Ginetta Parts Credit may be exchanged for parts only as supplied by Ginetta Cars. For the avoidance of doubt, Parts Credit cannot be used against entry fees, labour costs, lease costs or vehicle acquisition payments. Parts Credit must be redeemed within a 12 month period of being issued to the driver.

8.15.5 Parts Credit must be used by the driver it has been issued to and is non-transferable. All free entry prizes are for the driver in receipt of the prize and are non-transferable.

## **8.16 CHAMPIONSHIP LIVERY**

8.16.1 Approved Ginetta Championship stickers must be fixed to each competing car. Please see **5.3** for further details. See **Appendix A**.

8.16.2 All surfaces which have not been claimed for stickers by Ginetta its sponsor companies or used for the application of starting numbers are free for use. Conflicting sponsor's stickers must be approved by the Championship Coordinator in advance and the position and size and colours (if approved) will be at the discretion of the Championship Coordinator.

8.16.3 Each driver must wear the approved Ginetta Championship race suit which includes approved Championship badges. The Championship organisers reserve the right to remove any badges or branding which is deemed to be unsuitable or conflicts with other Championship / Ginetta sponsors. See Appendix A.

## 9. 2024 SUPPORT SERIES ENVIRONMENTAL GUIDELINES 2024 CIRCUIT GREEN CHARTER GUIDELINES

9.1.1 The following guidelines address the topics of the Series' carbon emissions, water and waste management and recommend best practice procedures to be put in place by the participating Series, in order to improve the event's environmental footprint. Following the listed guidelines will contribute towards more sustainable operations, which will benefit the overall environmental performance of the Series as well. The guidelines were compiled in accordance with current environmental policies for carbon reduction and carbon footprint improvement.

### 9.2 CARBON EMISSIONS

9.2.1 **Carbon Emissions:** Carbon reporting: Series to provide SRO with all required data sets for accurate measure of footprint, when requested, including details of:

9.2.2 All employee travel related to the event (number of employees, distances travelled and modes of transport used);

9.2.3 Relevant logistics operations run in preparation for the race event (quantity of fuel consumed, total freight moved (kg) and modes of transport used);

9.2.4 Any events emissions (all forms of fuel consumed at events for scooters, series operated cars, generators and equivalents);

9.2.5 Total distance driven by series operated scooters, cars, trucks and machinery at event;

9.2.6 Total electricity consumed at facilities away from tracks;

9.2.7 **Carbon neutrality:** Series to create a carbon reduction plan and management strategy for their carbon emissions where possible for race weekends, including generators use, mains electricity use and event vehicles (if not already in place).

9.2.8 **Facilities electricity:** Series to commit to using 100% renewable electricity by 2025 at the latest and create a transition road map for how this will be achieved (at facilities away from track).

9.2.9 **Event vehicles:** Series to create and implement a plan to minimize the use of fossil fuel powered vehicles through a reduction in kilometres driven at events and switching to lower/zero carbon options (e.g. e-vehicles).

9.2.10 **Scooters:** Series to minimize the use of fossil fuel powered scooters, if any, across paddock transportation, either through replacement with e-scooters, or reduction in use of traditional scooters.

9.2.11 **Generator use:** Series to create a road map for full replacement of all ICE generators with lower/zero carbon alternatives by 2025 at the latest;

9.2.12 Series to eradicate use of space heaters if currently used; Lower carbon diets: Series to offer at least one vegetarian and one vegan meal option to guests within the series' hospitality sites.

9.2.13 **Logistics:** Series to transition all logistics trucks to be at least Euro6 standard to limit carbon and air quality impacts from logistics.

9.2.14 **Employee travel:** Series to introduce employee travel carbon reduction plans, which should include:

- Limiting/ reducing the number of employees taken to each race where possible;
- Prioritizing lower carbon forms of travel such as train travel or car travel rather than

- flying;
- Increasing the hire of EVs/ Hybrids for transportation where possible;
  - Carbon compensation for all flights in cases where flying is unavoidable;

### **9.3 WATER**

#### **9.3.1 Water consumption:**

9.3.2 Avoid excessive washing of trucks in the paddock area, to reduce total paddock water consumption;

9.3.3 Fix and prevent all possible leaks during race weekends;

9.3.4 Clean discharge: Series to work with circuits to ensure all waste water discharged is done so in a safe manner, and does not cause any contamination of water causes or the local environment.

9.3.5 Chemicals: Series to work with circuits to ensure all chemicals used are safely discharged in the appropriate manners.

### **9.4 WASTE**

9.4.1 **Waste management and recycling:** Series to ensure all waste created is correctly separated and fed into circuits existing recycling infrastructure;

9.4.2 Series to create a waste minimization plan to reduce total quantity of waste generated at race weekends;

9.4.3 Series to ensure all participating teams follow waste management and recycling practices;

9.4.4 **Single use plastic:** Series to eliminate the use of single use plastic across their paddock by switching to reusable alternatives for all existing single-use plastic;

9.4.5 Series to communicate that they are single-use plastic free through communication channels;

9.4.6 **Food waste:** Series to correctly separate all food waste and other compostable materials generated, and work with circuits to ensure it can be centrally collected for composting or similar (dependent on circuits infrastructure).

9.4.7 **Tyre collection:** Series to work closely with tyre partner to facilitate the collection and recycling of 100% of tyres used at race weekends.

## 10. CHAMPIONSHIP CONTACTS

### 10.1 CHAMPIONSHIP CONTACTS AND RACE ORGANISING CLUBS

#### Vehicle Manufacturer

Ginetta Cars Ltd  
Helios 47  
Garforth  
Leeds  
Tel: 0845 210 5050  
E mail: [enquiries@ginetta.com](mailto:enquiries@ginetta.com)  
Website: [www.ginetta.com](http://www.ginetta.com)

#### Control Fuel Supplier

Petrochem Carless  
Cedar Court  
Guildford Road  
Leatherhead  
Surrey  
KT22 9RX  
Tel: 01372 360 000  
Fax: 01372 380 400

#### Eligibility Scrutineer:

Ron Humphreys  
Email:  
[ronhumphreys.motorsport@virginmedia.com](mailto:ronhumphreys.motorsport@virginmedia.com)

#### Control Fuel Distributor

Vital Equipment Ltd  
Orchard Lea  
Pontrilas  
Hereford  
HR2 0EL  
Tel: 05601 168546

#### Championship Organiser

British Racing & Sports Car Club  
Suite 21, 50 Churchill Square, Kings Hill,  
West Malling, ME19 4YU  
Tel: 01732 780 100  
E-mail: [enquiries@brscc.co.uk](mailto:enquiries@brscc.co.uk)

#### Paddock Layout Team

MSO  
Derek Weller  
Tel: 01162 593808  
Email: [Derek@m-s-o.co.uk](mailto:Derek@m-s-o.co.uk)

#### Championship Coordinator

Kelly Edmund  
Tel: 07917 261 345  
Email: [kelly.edmund@ginetta.com](mailto:kelly.edmund@ginetta.com)

#### Governing Body

Motorsport UK  
Bicester Motion  
OX27 8FY  
Tel: 01753 765000

#### Ginetta Parts Department

Tel: 0113 385 4164  
Email: [parts@ginetta.com](mailto:parts@ginetta.com)

#### Tyre Distributor

Protyre Motorsport  
Tel: 01782 411001  
Email: [sales@protyremotorsport.co.uk](mailto:sales@protyremotorsport.co.uk)

## APPENDIX A

### GT ACADEMY

### GINETTA DECAL DETAILS

WINDSCREEN BANNER - GT ACADEMY



FRONT + REAR PIRELLI LOGO



SILL STICKERS - BRSCC/PROTYRE/CARLESS



NUMBER BOARD-BONNET & BOTH SIDES



GTA WINDSCREEN NUMBER - FLURO YELLOW

GTA ROOKIE ONLY WINDSCREEN FRONT & REAR STRIP - FLURO YELLOW

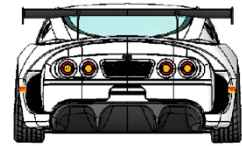
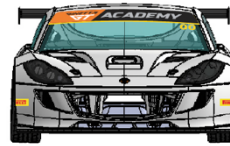
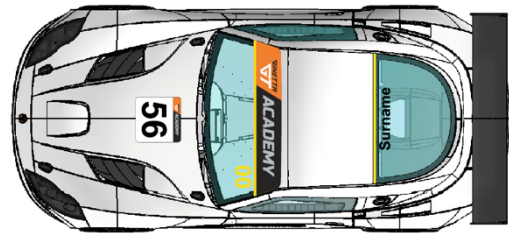
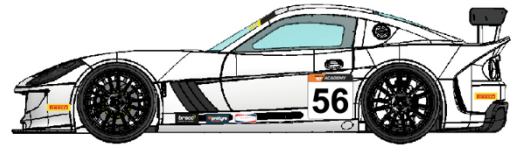

## APPENDIX B





## APPENDIX C



A socially-minded standard of behaviour is expected from everyone within the motorsport community.

By participating in a Motorsport UK event in any capacity you agree to follow the values of the Respect Code:

[Motorsportuk.org/racewithrespect](https://Motorsportuk.org/racewithrespect)  
[#RaceWithRespect](https://twitter.com/RaceWithRespect)

### The Values

- Respect
- Integrity
- Self-Control
- Fair play
- Good Manners

I pledge to #RaceWithRespect and:

- Contribute to a welcoming and friendly environment that ensures the safety and welfare of all participants.
- Always behave with integrity and uphold fairness in the sport; play my part in keeping the sport safe through your actions
- Treat everyone with respect, regardless of their gender, ethnic or social background, language, religious or other beliefs, disability, sexual identity or other status
- Recognise that we all represent the sport and therefore have a duty to be polite and respectful to all staff, officials, fellow competitors, volunteers, as well as fans and supporters
- Respect the rules, regulations and authority of the officials and Motorsport UK

Any breach of these obligations may result in disciplinary action.