

# FIESTA JUNIOR

CHAMPIONSHIP

## 2026 BRSCC Fiesta Junior Championship Sporting & Technical Regulations

PUBLISHED COPY

Signed: Esther Crook  
Esther Crook (Mar 27, 2026 05:47:08 GMT)  
ESTHER CROOK - CHAMPIONSHIP COORDINATOR

Date: 26/03/2026

<b>CONTENTS</b>		<b>Page</b>
<b>1</b>	<b>SPORTING REGULATIONS – GENERAL</b>	<b>2</b>
1.1	Title & Jurisdiction	2
1.2	Officials	2
1.3	Competitor Eligibility	3
1.4	Registration	4
1.5	Championship Events	5
1.6	Scoring	5
1.7	Awards	6
<b>2</b>	<b>CHAMPIONSHIP EVENTS &amp; RACE PROCEDURES</b>	<b>8</b>
2.1	Entries	8
2.2	Briefings/Meetings	8
2.3	Qualification Practice	8
2.4	Races	9
2.5	Starts	9
2.6	Session Red Flag	9
2.7	Pits, Paddock & Pitlane Safety	10
2.8	Race Finishes	11
2.9	Results	11
2.10	Timing Modules	11
2.11	Qualification Races	11
2.12	Operation Of Safety Car	11
2.13	Onboard Cameras	11
2.14	Parc Fermé	12
<b>3</b>	<b>SPECIFIC CHAMPIONSHIP REGULATIONS</b>	<b>13</b>
3.1	Motorsport UK's Respect Code	13
3.2	Re-Scrutiny	13
<b>4</b>	<b>SPECIFIC CHAMPIONSHIP PENALTIES</b>	<b>14</b>
4.1	Infringements Of Technical Regulations	14
4.2	Additional Specific Championship Penalties	14
4.3	Social Media	15
<b>5</b>	<b>TECHNICAL REGULATIONS</b>	<b>16</b>
5.1	Introduction	16
5.2	General Description	16
5.3	Safety Requirements	17
5.4	General Technical Requirements & Exceptions	19
5.5	Chassis	19
5.6	Bodywork	20
5.7	Engines	23
5.8	Suspensions	26
5.9	Transmissions	27
5.10	Electrics	28
5.11	Brakes	29
5.12	Wheels/Steering	30
5.13	Tyres	30
5.14	Vehicle Weight	33
5.15	Fuel Tank And Fuel	33
5.16	Silencing	33
5.17	Competition Numbers/Decals	33
<b>6</b>	<b>APPENDICES</b>	<b>35</b>
6.1	Race Organising Clubs & Contacts	35
6.2	Commercial Undertakings	35
6.3	<i>Deleted</i>	36
6.4	<i>Deleted</i>	36
<b>7</b>	<b>REGULATORY APPENDICES</b>	<b>37</b>
7.1	<i>Deleted</i>	37
7.2	Mandatory & Optional Parts List	37

## 1. SPORTING REGULATIONS – GENERAL

### 1.1 TITLE & JURISDICTION

The 2026 BRSCC Fiesta Junior Championship is organised and administered by the British Racing & Sports Car Club (BRSCC) in accordance with the National Competition Rules (NCR) of Motorsport UK (incorporating the provisions of the International Sporting Code of the FIA) and these Championship Regulations.

Motorsport UK Championship Permit No – CH2026/RVD002

Race Status – Interclub

Motorsport UK Championship Grade - D

The BRSCC reserves the right to amend or vary the Sporting Regulations in accordance with NCR Ch.3 App.10 Art.4.2 at any time before or during the Championship and further issue additional statements concerning the Regulations from time to time, subject to Motorsport UK approval, and all such statements will be issued by Championship Bulletin to Motorsport UK and to all registered competitors by email or by post to the address detailed on the Registration Form, or by delivery to the competitor by hand. It is a condition of entry into the championship that all competitors, teams, team members and persons associated with any of the above agree to be bound by the Regulations including any amendments, variations or statements relating thereto.

### 1.2 OFFICIALS

#### 1.2.1 Championship Co-ordinator

Esther Crook  
Mob: 07713 165935  
Email: [fiestajunior@brscc.co.uk](mailto:fiestajunior@brscc.co.uk)

#### 1.2.2 **Championship Eligibility Scrutineer** [Matthew Godber \(or his appointed deputy\)](#) [Mobile: 07751 647841](#) [Email: fiestatechnical@brscc.co.uk](mailto:fiestatechnical@brscc.co.uk)

#### 1.2.3 **Championship Clerk of the Course** [Paul Levitt \(or his nominated deputy\)](#) [Tel: 07815 908928](tel:07815908928) [Email: paul@hareandlevitt.co.uk](mailto:paul@hareandlevitt.co.uk)

#### 1.2.4 **Championship Stewards**

D Scott, S Stringwell, D Evans & S Roach

Any three Championship Stewards will constitute a quorum. In the event of any of the Championship Stewards listed above being unavailable or being unable to consider any particular matter due to a perceived conflict of interest, the organisers reserve the right to appoint an alternative Championship Steward or, if deemed to be necessary, more than one alternative Championship Steward.

**NCR Ch.4 App.1 Art.1.2** The Championship Stewards can only adjudicate upon any disputes irregularities or appeals arising from the published Championship Regulations. They are also empowered to consider

any request from the Championship Co-ordinator to penalise any Competitor for any breach of Championship Regulations and after holding a formal hearing those Stewards may impose a penalty in accordance with NCR Chapter 2 subject to the rights of Appeal to the National Court there provided.

### 1.3 COMPETITOR ELIGIBILITY

#### 1.3.1 Entrants must:

- (a) be fully paid up valid membership card holding members of the BRSCC and
- (b) be registered for the Championship and
- (c) be in possession of a valid Motorsport UK Entrants Licence

#### 1.3.2 Drivers and Entrant/Drivers must:

- (a) be current Members of the BRSCC and
- (b) be Registered for the Championship and
- (c) be in possession of valid Motorsport UK or Motorsport Ireland Competition (Car Racing) Race Club status Licence endorsed "Junior Championship UK Only" and valid for the championship; or, be in possession of the highest grade of national Race licence or valid FIA International Licence, including confirmation of a valid medical certification, together with their ASN's written consent (FIA ISC Article 2.3.7 applies). Art. 1.3.2 (d) also applies.
- (d) In accordance with NCR Ch.12 App.1 Art.1.13, a licence issued by another ASN outside the UK will be deemed valid, subject to specific written confirmation from the Licensing ASN; and satisfactory completion by that competitor of the extended ARDS course specifically designed for Junior Car Racing.
- (e) If participation in the Championship requires absence from education a driver, in full time school education is required to have the approval of their head teacher and a letter stating such approval from the school in order to fulfil registration for the Championship. A driver shall not take time out of their education to participate in motor sport without the prior written approval of their education establishment.
- (f) Drivers are eligible to compete in the Championship once they have achieved their 14th birthday. Drivers whose 17th birthday is on or after the 1st January in the current year of the Championship are eligible for the whole of that year (until 31st December). NCR Ch.12 App.1 Art.1.7 refers.

#### 1.3.3 Teams

Definition: A Team is a commercial race company or racing team hosting drivers in providing race services or covered accommodation in the Championship and as a result receives financial gain where, in respect of Junior Championships, the principal is not also the PG Entrant licence holder. Being considered as being a Team includes the use of team names, team sticker kits and team race suits/clothing.

A Team shall at all times uphold and respect the provisions of the Code, the National Competition Rules and these Championship Regulations as may be amended from time to time and shall;

- (a) hold a valid Motorsport UK Entrant licence;
- (b) have at least £5 million Public Liability Insurance;
- (c) uphold the values of the Respect Code and all applicable Motorsport UK policies and guidance;
- (d) act in a professional manner at all times and not act or permit any member of the Team to act in such a manner as to bring motor sport, the Championship or Motorsport UK or any its officers and officials into disrepute;
- (e) adhere to the Motorsport UK Safeguarding Policy and guidance documents, complete Safeguarding training when required and ensure that any person undertaking Regulated Activity is the holder of a valid DBS certificate supplied through Motorsport UK;
- (f) ensure that representative(s) and driver coaches attend training/briefing when required;

- (g) adhere to the National Competition Rules in respect of anti-alcohol and illicit drugs as well as Motorsport UK processes for anti-alcohol and illicit drugs testing;
- (i) nominate one member of their Team as the Team Representative at each Event including but not exclusively for the purpose of all judicial proceedings at Events and who shall be present at all judicial proceedings concerning drivers entered under that Team licence in substitution for the driver Parent/Legal Guardian.

1.3.3.1 It is recommended the Team has:

- (a) a designated team member as a 1st 4Sport, Level 2 qualified coach;
- (b) a designated UKAD Certified Advisor, and
- (c) be responsible for carrying out and documenting a risk assessment of their activities; (risk assessment management tool available from Motorsport UK)

1.3.4 All competitors must sign-on at Events that they compete in. This includes drivers, parent/guardian for under-18's, Team Entrant (as per Entrant Licence). All necessary documentation must be available to be presented for checking at all times upon the demand of the Officials.

1.3.5 Competitors not registered for the Championship may be permitted on an individual round basis and will:

- (a) Be deemed "Guest Competitors"
- (b) Not score points and for the purpose of points scoring will be ignored
- (c) Qualify for Event awards
- (d) Comply with the eligibility as prescribed in Article 1.3 above, with the exception of 1.3.1(b) and 1.3.2. (b), as appropriate.
- (e) Pay a £45.00 Guest Competitors Administration Fee for each round as a guest (in addition to the entry fee for that event)

1.3.6 Competitors must ensure that their cars comply with the conditions of eligibility and safety throughout qualifying and racing.

## 1.4 REGISTRATION

1.4.1 All drivers and Team Entrants must register as competitors for the Championship by returning the online Registration Form with the Registration Fee to BRSCC prior to the Final Closing date for the first round being entered.

1.4.2 The Registration Fee is £695.00. Made payable to BRSCC.

1.4.3 Registration numbers will be the permanent Competition numbers for the Championship.

1.4.4 Registrations will be accepted from the 15<sup>th</sup> January 2026 until the closing date for the last round.

1.4.5 Registrations will be accepted in accordance with NCR Ch.12 App.1 Art.1.7.

1.4.6 Acceptance or rejection of registration is entirely at the discretion of the organisers.

1.4.7 Deleted.

1.4.8 From the age of 16 a driver may hold their own full Motorsport UK race licence, however, by doing so will no longer be able to compete in this championship.

## 1.5 CHAMPIONSHIP EVENTS

1.5.1 The 2026 BRSCC Fiesta Junior Championship will be contested at the following venues:

ROUNDS	DATE	VENUE	ORGANISING CLUB
1, 2 & 3	18 <sup>th</sup> & 19 <sup>th</sup> April 2026	Snetterton 300*	BRSCC
4 & 5	16 <sup>th</sup> May 2026	Silverstone GP*	BRSCC
6, 7 & 8	13 <sup>th</sup> & 14 <sup>th</sup> June 2026	Anglesey International*	BRSCC
9 & 10	18 <sup>th</sup> & 19 <sup>th</sup> July 2026	Donington Park National*	BRSCC
11, 12 & 13	15 <sup>th</sup> & 16 <sup>th</sup> August 2026	Brands Hatch Indy*	BRSCC
14, 15 & 16	19 <sup>th</sup> & 20 <sup>th</sup> September 2026	Silverstone National*	BRSCC
17 & 18	17 <sup>th</sup> October 2026	Oulton Park International*	BRSCC

\* Subject to a valid track licence

[1.5.2 Alternative Championship Rounds may be organised in accordance with NCR Ch.12 App.2 Art.4.](#)

## 1.6 SCORING

1.6.1 Points will be awarded based on overall finishing positions to Competitors listed as classified finishers in the Final Results as follows:

1 <sup>st</sup>	2 <sup>nd</sup>	3 <sup>rd</sup>	4 <sup>th</sup>	5 <sup>th</sup>	6 <sup>th</sup>	7 <sup>th</sup>	8 <sup>th</sup>	9 <sup>th</sup>	10 <sup>th</sup>
50 points	46 points	42 points	38 points	36 points	34 points	32 points	30 points	28 points	26 points
11 <sup>th</sup>	12 <sup>th</sup>	13 <sup>th</sup>	14 <sup>th</sup>	15 <sup>th</sup>	16 <sup>th</sup>	17 <sup>th</sup>	18 <sup>th</sup>	19 <sup>th</sup>	20 <sup>th</sup>
24 points	22 points	20 points	18 points	16 points	14 points	12 points	10 points	8 points	6 points
21 <sup>st</sup>	22 <sup>nd</sup>	23 <sup>rd</sup> down							
4 points	2 points	1 point							

In addition, the following points will be awarded where the specified conditions have been met:

- i) Starting the first race at each event in Pole position, having set the fastest lap time in the correct qualifying session: 1 point. The competitor does not need to be a classified finisher in the race to receive this point. If the fastest qualifier does not subsequently start the first race from pole position the point will not be awarded to this or any other competitor.
- ii) Fastest Race Lap, set at any point in each race: 2 points. The competitor must be a classified finisher in the race to receive these points and, if not, the points will not be awarded to this or any other competitor.

Should any competitor in the Championship not participate in any of the first 16 races (or pro-rata reduction if the number of rounds is reduced) they will be eligible for any awards gained per race thereafter but will not score points and they will be considered invisible for the allocation of championship points.

1.6.2 For the Overall Championship scores, the totals from all qualifying rounds held, less three will determine the final Championship points and positions. Drivers disqualified from results for sporting or technical

infringements may not use that (those) round(s) as discarded rounds for the purpose of overall championship placing. Drop scores must include any points for fastest lap and/or pole position accrued in respect of the dropped rounds. Unless a competitor has duly entered and takes part in the final championship event, competitors will NOT be able to drop scores from the final event.

1.6.3 Ties will be resolved in accordance with NCR Ch.4 App.3 Art.4.

1.6.4 Where the race distance has been reduced (2.6) it shall still count as a full points scoring round.

1.6.5 [Refer to Art. 1.3.5 regarding Guest Competitors.](#)

1.6.6 All year end results are provisional until announced as official by the organisers, that includes tables published on all BRSCC official websites.

## 1.7 AWARDS

1.7.1 All awards are to be provided by the Organising Club.

### 1.7.2 Per Round

Trophies to 1<sup>st</sup>, 2<sup>nd</sup> and 3<sup>rd</sup> place.

### 1.7.3 Championship

**Overall Championship** - Trophies will be awarded to the Champion (1<sup>st</sup> Place) and 2<sup>nd</sup> and 3<sup>rd</sup> place finishers in the Championship.

**Teams Champion** - A team entrant qualifies for the award if they have two or more drivers and are registered for the championship in accordance with Art. 1.3.1 and Art. 1.3.3 of these Championship Regulations. Teams will be awarded points at the end of each race equivalent to the number of points scored by their two highest scoring drivers in each race. There will be no dropped scores.

**Independents Cup** - An 'Independent' is a competitor who does not use the services or have any support of a registered team entrant (Art. 1.3.1 and Art. 1.3.3 refer) to run their car during the championship season. The highest placed Independent driver in the final Championship standings (see Art. 1.6.1) will receive a trophy. Should an 'Independent' use the services of a registered team entrant at any time during the Championship, they will become ineligible for the Independents Cup.

**Rookie Cup** - A competitor in their first season competing in the championship or a competitor who has competed in less than 4 Junior championship races previously will be eligible to score points for the Rookie Cup. The competitor fulfilling this criteria who has gained the most championship points at the conclusion of the season will be awarded the Rookie Cup trophy.

### 1.7.4 Presentations

Awards will be presented at the end of each round, or at the subsequent [Event](#) if necessary. End of season awards will be presented at a designated end of season presentation ceremony.

### 1.7.5 Entertainment Tax Liability

[Prize money and Bonuses shall be posted to the Entrants within 7 days of the results being declared final after each Event.](#)

In accordance with current UK government legislation, the Organiser is legally obliged to withhold income tax at the basic rate (currently 20%) on all payments to non-UK resident sportspersons and entertainers, and to account for this to HMRC using form FEU1, the quarterly return of payments made to non- resident entertainers and sportspersons.

A non-UK resident is defined as someone who does not have a normal permanent residence in the UK. The UK does not include the Isle of Man, Channel Islands or the Republic of Ireland. This means that, as the organiser, the BRSCC is required to deduct tax at the current rate applicable from any such payments they may make to non-UK residents.

Under certain circumstances, competitors may apply to HMRC for a reduced withholding tax rate, or for an exemption, if they can demonstrate that the standard deduction exceeds their actual UK tax liability. Such applications must be submitted in writing **at least 30 days before the payment is due.**

For further information contact:- Charities, Savings and International 1, HM Revenue and Customs, BX9 1AU. Tel: 0300 322 7877

#### 1.7.6 **Title to all Trophies**

If Provisional Results or Championship Tables are revised after any presentations and these revisions affect the distribution of any awards the competitors concerned must return such awards to the organisers in good condition within 7 days of them being requested to allow them to be reallocated.

1.7.7 The organisers reserve the right to arrange and introduce additional awards/bonuses for and during the Championship.

## 2. CHAMPIONSHIP EVENTS & RACE PROCEDURES

### 2.1 ENTRIES

- 2.1.1 Competitors are responsible for sending in correct and complete entries with the correct entry fee prior to the closing date for entries before each event.
- 2.1.2 Incorrect or incomplete entries (Including Driver to be Nominated Entries) are to be held in abeyance until they are complete and correct and the date of receipt for acceptance of entry purposes shall be the date on which the [Event](#) Organiser receives the missing or corrected information or fee.
- 2.1.3 Any withdrawal of Entry or Driver/Car changes made after the acceptance of any entry must be notified to the [Event](#) Organisers in writing. NCR Ch.3 App.11 Art.1.1.1 applies.
- 2.1.4 The Entry Fee for each event shall be specified in the SRs and on the entry form.
- 2.1.5 Reserves will be listed in the Final List of Entries published with Final Instructions or in a Bulletin.

### 2.2 BRIEFINGS / MEETINGS

Organisers [must](#) notify competitors of the times and locations for all briefings in the Final Instructions for the [Events](#). Competitors and parents/guardians must attend all briefings. If a driver or their parent/guardian representative misses a briefing the competitor may be liable to a penalty. [Any Written briefing is an Official Document.](#)

As part of a BRSCC Young Driver Development Programme, competitors may be invited to attend additional online or live meetings with BRSCC appointed personnel. These meetings will be structured to assist Junior Drivers in the advancement of their motorsport skills, understandings and responsibilities. At these meetings it may be a requirement that each competitor is accompanied by a parent or guardian, and/or Team Representative/Driver Coach (if requested). If a driver or their parent/guardian/team representative/driver coach misses a meeting that they are required to attend, the competitor may be liable to a penalty.

### 2.3 QUALIFICATION PRACTICE

- 2.3.1 Should any practice session be disrupted the Clerk of the Course shall not be obliged to resume or re-run the session; the decision of the Clerk of the Course shall be final.
- 2.3.2 Each driver [must](#) complete a minimum of 3 laps in the car to be raced and in the correct session in order to qualify. NCR Ch.12 App.6 Art.3.1 applies.
- 2.3.3 Limitations to pre-race practice: Registered drivers or their cars are only permitted to practice once at any specific circuit configuration hosting a round of the Championship within a period of 21 days prior to the date of that round, this in addition to practice or test sessions immediately prior to or during an event, as authorised by the organisers.
- 2.3.4 The grid for the first race of an event will be set by qualifying times. The grid for the second race will be set by the finishing order of the first race. For triple-header events, the grid for the third race will be set by the finishing order of the second race.
- 2.3.5 If mechanical means are used by the marshals to remove the car to a safe position, the car concerned cannot re-join the session. Where deemed necessary, the Clerk of the Course may at his sole discretion

allow a car to re-join the session but any future laps it completes in that session will not be timed or will be disallowed.

2.3.6 At the end of each session, all drivers must cross the Finish Line only once.

## 2.4 RACES

2.4.1 Should any race be disrupted the Clerk of the Course shall not be obliged to resume or rerun the race (NCR Ch.12 App.6 Art.9.3) (1.6.4. above applies).

2.4.2 If mechanical means are used by the marshals to remove the car to a safe position, the car concerned cannot re-join the session.

2.4.3 At the end of each session, all drivers must cross the Finish Line only once.

## 2.5 STARTS

2.5.1 All cars will be released to form up on the grid prior to the start in formation as specified on the grid sheet. Grids may be formed in a 1 x 1 formation or in a staggered 2 x 2 formation depending on the venue and circuit layout. The grid format for each event will be confirmed in the final instructions or by Event Bulletin.

2.5.2. The start will be via a standing start.

The minimum countdown procedures/audible warning sequence shall be:

I. 1 minute to start of Green Flag lap - Start Engines/Clear Grid.

II. 30 Seconds - Visible and audible warnings for the start of Green Flag lap.

III. After completion of the Green Flag Lap vehicles will resume their Grid positions for a standing start.

IV. A five second board will be used to indicate that the grid is complete after the green flag lap.

V. The red lights will be switched on five seconds after the board is withdrawn and switched off to indicate the start of the race.

2.5.3 Any cars removed from the grid after the 1 minute stage or driven into the pits on Green Flag Lap shall be held in the pitlane and may start the race after the last car to take the start from the grid has passed the start line or pitlane exit, whichever is the later.

2.5.4 Any driver unable to start the Green Flag Lap or start the race are required to indicate their situation as per NCR Ch.12 App.6 Art.6.11. In addition any driver unable to maintain their grid position on the Green Flag Lap to the extent that ALL other cars are ahead of them, may complete the Green Flag Lap but MUST remain at the rear of the last row of the grid but ahead of any cars to be started with a time delay.

2.5.5 In the event that the starting lights fail the Starter will revert to using the National Flag.

## 2.6 SESSION RED FLAG

2.6.1. Should the need arise to stop any race or practice, RED LIGHTS will be switched on at the Start Line and RED SIGNALS will be displayed at the start line and at all Marshals Signalling Points around the circuit.

This is the signal for all drivers to cease circulating at racing speeds, to slow to a safe and reasonable pace and to return to the pit lane, during practice, and to the starting grid area, during a race, which will automatically become a parc ferme area, unless otherwise directed by officials. Marshals should revert to displaying yellow flags to indicate to Drivers the particular location of any incident, hence supplementing the Light Panels.

Cars should not enter the pits unless directed to do so and all cars in the pit lane during a red flag period must take any restart from the pit exit.

**2.6.2. Case A – Less than two race laps completed by the race leader.**

The race will be declared a “No Contest” and available competitors will restart from their original grid positions. Competitors unable to take the restart may be replaced by reserves who will start from the back of the grid in reserve order. Gaps on the grid should not be closed up. The Clerk of the Course may order that the duration of the re-run of any race shall be a shorter distance than originally scheduled or may be abandoned altogether. The duration of the re-run will be determined as the duration of the race.

**2.6.3. Case B – More than two race laps completed by the Race Leader but less than 75%**

Any race stopped after the leader has completed more than two laps but less than 75% of its duration will be considered as the first part of the race. Competitors will be restarted from a grid set out in the finishing order of this first part, which shall be based upon the order of crossing the finish line at one lap less than the number of laps completed by the leader at the time of first showing the Red Signal. Only vehicles which are proceeding under their own power, in accordance with NCR Ch.12 App.8 Art.1.7.j at the showing of the Red Signal will be classified in this first part (NCR Ch.12 App.6 Arts.9.1.c and NCR Ch.12 App.6 Arts.9.2-9.3 also apply). The result of the race will be the finishing order at the end of the restarted race (see NCR Ch.12 App.6 Arts.9.1.d).

**2.6.4 Case C - More than 75% of race completed**

If the leader has completed more than 75% of the race distance or duration it shall not be restarted and the results will be declared in accordance with NCR Ch.12 App.6 Arts.9.1.e, unless the Clerk of the Course, in consultation with the Stewards deems it appropriate to restart the race.

**2.7 PITS, PADDOCK & PITLANE SAFETY**

**2.7.1 Pits & Paddock**

Competitors must ensure that the Motorsport UK, Circuit Management and Organising Club Safety Regulations are complied with at all times.

**2.7.2 Pit Lane**

The outer lane or lanes are to be kept unobstructed to allow safe passage of cars at all times. The onus shall be on all Drivers to take due care and respect the pit lane speed limits. All drivers, teams and pit crew members must familiarise themselves and comply with NCR Ch.12 App.11 Art.3.6

**2.7.3 Refuelling**

May only be carried out in accordance with the NCR, the Organising Club Regulations, Circuit Management Regulations and the SRs or Final Instructions issued for each Circuit / Event.

#### 2.7.4 **Speed Limit**

Pit Lane Speed Limit will be 60kph unless otherwise advised in event Final Instructions.

### 2.8 **RACE FINISHES**

After taking the Chequered Flag drivers are required to:

- I. Progressively and safely slow down.
- II. Remain behind any competitors ahead of them
- III. Return to the pit lane/entrance as instructed
- IV. Comply with any directions given by marshals or officials
- V. Keep their helmets on and harness done up while on the circuit or moving in the pit lane.

All finishers in all races, plus any others instructed by an official to do so, must take their cars to scrutineering where post event eligibility checks may be carried out. Failure to comply will result in disqualification from the event.

### 2.9 **RESULTS**

All Practice Timesheets, Grids, race Results are to be deemed PROVISIONAL until all vehicles are released by Scrutineers after Post Practice/Race Scrutineering and/or after completion of any Judicial or Technical Procedures. NCR Ch.3 App.6 Art.1.4 applies.

### 2.10 **TIMING MODULES**

2.10.1 All competitors will be required to fit Electronic Self Identification Modules (transponders) to their cars for the purposes of accurate timing. The Modules must be in place and functioning correctly for all championship qualifying practice sessions and races.

The setting and servicing of these items must only be carried out by properly authorised Motorsport UK licensed Timekeepers.

Competitors who have rented transponders from the official timekeepers will be charged by the timing company for replacement of the Modules due to misuse or loss at any time during the season.

NCR Ch.12 App.6 Art.2.2 applies.

2.10.2 Competitors may not place electronic timing equipment within five metres of the official Start, Finish or any other official timing lines at any event or test session/day. Any such equipment placed within these zones will be removed.

### 2.11 **QUALIFICATION RACES**

If any event is oversubscribed the Organising Club may at their discretion run Qualification Races. Details will be provided in the Final Instructions or by event bulletin.

### 2.12 **OPERATION OF SAFETY CAR**

The Safety Car will be brought into operation and run in accordance with NCR Ch.12 App.8 Art.2.

### 2.13 **ONBOARD CAMERAS**

All cars must have an HD camera video data system in a place with camera positions which will give a forward facing view out of the vehicle to give a view of the track ahead and some of the nearside view

out of the nearside passenger window. NCR Ch.7 App.9 applies. All cars must also be fitted with a rear facing HD video camera which gives a clear view of the track behind.

The above units must be switched on and recording at all times when the car is on track during any official free practice, qualification session and race. The onus is on the competitor to ensure that the unit battery is charged and camera switched on to record during the above mentioned sessions. The memory card/method of video storage may be removed by the Championship Coordinator, Eligibility Scrutineer or their assistants for any purpose and the recorded footage copied for use in broadcast or any other area deemed appropriate by the championship organiser. Failure to make available to the championship organiser the recorded session video on the memory card/method of video storage when requested will be deemed to be an obstruction and the facts reported to the Clerk of the Course. Should a competitor fail to make available to the Clerk of the Course the memory cards or video footage, the Clerk of the Course may impose a penalty as defined in NCR Chapter 2.

Memory cards of not less than 16Gb capacity (32Gb recommended) must be used and each card clearly marked with the allocated competitor number. This will aid identifying the relevant competitor for return of card.

## **2.14 PARC FERMÉ**

At all race events the showing of the Chequered Flag (for both Qualifying and Racing) will indicate the commencement of Parc Fermé Regulations. Any vehicle that is in the pit lane at this time will be under Parc Fermé rules.

It is prohibited to work on any vehicle after the chequered flag has been shown. This includes tyre pressure checking, wheel changes or changes of driver unless authorised by the Eligibility Scrutineer or their Deputy.

Any vehicle in the pit lane must be immediately taken to the designated Parc Fermé area. No team personnel may enter Parc Fermé unless authorised by the Eligibility Scrutineer or their Deputy.

No tools of any type may be passed by team members or mechanics to drivers whilst in Parc Fermé.

Competitors are reminded that the area designated as Parc Fermé area is a secure area and it is not permitted for any supporters to be in Parc Fermé unless at the behest of the eligibility scrutineer or their deputy.

### 3. SPECIFIC CHAMPIONSHIP REGULATIONS

#### 3.1 MOTORSPORT UK'S RESPECT CODE

By registering for the Championship all competitors and their associates commit to positively promote and demonstrate the Motorsport UK's Respect Code which is appended to these regulations (Appendix 1).

- 3.1.1 Where any reports of disrespectful conduct are judged to be well founded the Championship organisers may issue warnings or require remedial actions and/or report the matter to the Championship Stewards who may impose appropriate penalties which can include loss of Championship points and/or race bans through to [Disqualification from further participation in the Championship](#) and referral to Motorsport UK.
- 3.1.2 It is imperative that we promote the safety and wellbeing of young people and adults at risk. In addition to this all participants must be aware of their behaviour and conduct at all times and abusive language and harmful behaviour will not be tolerated. Any such incidents must be reported to the Championship Coordinator and/or Safeguarding Officer who will also relay the report Motorsport UK. Details of the Motorsport UK Policies and Guidelines are available at [www.motorsportuk.org/resource-centre](http://www.motorsportuk.org/resource-centre) by selecting Policies and Guidelines.

#### 3.2 RE-SCRUTINY

Any vehicle involved in a contact incident during any session or race must be re-presented to the scrutineers before taking part in any further session or race. NCR Ch.7 App.12 Art.1.5 applies.

#### 3.3 RACE CONTROL TO DRIVER RADIO

- 3.3.1 Deleted.
- 3.3.2 For all official sessions, including any Free Practice, Qualifying and Races, all competitors must use the mandatory 'Race Control to Car' radio receiver for which the transmitter shall be under the sole control of the Clerk of the Course and used to communicate instructions or warnings to the drivers from Race Control. See NCR Ch.12 App.4 Art.4.12.c.
- 3.3.3 Should a competitor not have a working receiver fitted during an official session or fail to comply with any message or instruction(s) from the Clerk of the Course, they may receive a penalty. The responsibility remains with the competitor to ensure their receiver is in full working order during all official sessions.
- 3.3.4 The mandatory receiver may only be purchased directly from the BRSCC.

#### 3.4 JUDICIAL HEARINGS

- 3.4.1 If a competitor is involved in a collision or incident, they must not leave the circuit (except where medically evacuated) without the consent of the Clerk of the Course, failing which, any judicial action against or relating to that Entrant / Driver may be heard in their absence.
- 3.4.2 When attending a judicial hearing, all drivers must be accompanied by a maximum of **ONE** guardian. Where the driver is entered with the support of a Team **Entrant**, in accordance with Article 1.3.3(g) of these regulations, the guardian must be a Team Representative nominated by that Team Entrant who will attend all judicial proceedings in place the drivers Parent/Legal Guardian.

#### 4. SPECIFIC CHAMPIONSHIP PENALTIES

In accordance with NCR Chapter 2 and these Championship Regulations.

##### 4.1 INFRINGEMENTS OF TECHNICAL REGULATIONS

###### 4.1.1 Arising from post practice Scrutineering or Judicial Action

Minimum Penalty: The provisions of NCR Ch.2 App.8 Arts.1.20-1.21.

###### 4.1.2 Arising from post-race Scrutineering or Judicial Action

Minimum Penalty: The provisions of NCR Ch.2 App.8 Arts.2.2a+b.

For infringements deemed to be of a more serious nature the Clerk of the Course and/or Stewards of the [Event](#) are to invoke the provisions of NCR Ch.2 App.8 Art.2.2.c.

##### 4.2 ADDITIONAL SPECIFIC CHAMPIONSHIP PENALTIES

4.2.1 In order to maintain standards of conduct, the Championship Coordinator/Organisers may monitor reports of adverse behaviour at race [events](#). If any individual (or member of their team/supporters/sponsor) is included on such reports, they may receive written warning from the Organisers that their driving/behaviour is to be specifically observed at future race [events](#). Any adverse reports during this period of observation could result in a Championship Stewards' enquiry, with possible loss of Championship points to the driver and team entrant. The organisers may also refuse further race entries.

This will include but is not limited or restricted to:

- Overly aggressive or dangerous driving
- Aggressive or threatening behaviour
- Abuse in any form
- Intimidation
- Discrimination
- Obtrusive Behaviour
- Any other action that is deemed to be detrimental to the Championship

4.2.2 Adverse behaviour (4.2.1) including offences under NCR Ch.2 App.1 Art.1.16 & Ch.2 App.1 Art.1.1, may be construed as bringing the championship into disrepute, and could attract a penalty as follows:

Receive a verbal or formal warning from the Championship Organisers. Be required to apologise to your fellow competitor(s) and/or Official(s). In addition the Championship Stewards may impose further penalties, which could include: A warning (which may also incur a deduction of 10 Championship Points); A 2nd and Final warning (which may also incur a deduction of 20 Championship Points); [Disqualification from further participation in the Championship \(which may also incur a deduction of all Championship Points scored\)](#). A Team may be forbidden to attend club [events](#). The matter may also be referred to the Motorsport UK who may consider whether there should be further penalty against the licenced Entrant/Team Entrant.

4.2.3 The Clerk of the Course reserves the right to impose a 'Stop-Go Penalty/Drive Through Penalty' in accordance with NCR Ch.12 App.10 Art.1.

4.2.4 Infringements of 2.13 (Onboard Cameras) may be liable to a Championship Penalty of a fine of up to £500.00 per offence, in addition to any penalty provided for by NCR Chapter 2.

- 4.2.5 When a penalty that incurs penalty points is imposed on a competitor by the Clerk of the Course or the Stewards of the [Events](#), a '3x points multiplier' championship penalty will also be incurred, whereby the number of penalty points will be multiplied by three and that number of championship points be deducted from that competitor's championship points total even if this results in a negative score.

### 4.3 SOCIAL MEDIA

Social media, including, but not restricted to, Facebook, Instagram, [X \(formerly Twitter\)](#) etc. is a powerful and wide-reaching medium for the expression of views and opinions, and the sharing of photographs and video. As such, competitors should be aware that their conduct on social media regarding the Championship, the BRSCC and its drivers should reflect the impact social media has. If a competitor is considered to have brought the Championship and the BRSCC into disrepute in the opinion of the Championship Stewards they may be subject to a penalty or [Disqualification from further participation in the Championship](#). Additionally, competitors are reminded that the Motorsport UK monitor social media and any remarks that are deemed to bring the sport into disrepute can lead to penalties.

## 5. TECHNICAL REGULATIONS

### 5.1 INTRODUCTION

The following Technical Regulations are set out in accordance with the Motorsport UK specified format and it should be clearly understood that if the following texts do not clearly specify that you can do it you should work on the principle that you cannot. Competitors are advised to read Motorsport UK NCR Ch.1 App1, Ch.7, Ch.8, Ch.9 and Ch. 12. Checking of any parts will be by comparison to spare parts as supplied by the manufacturer's official agent for the model of car being raced, or by comparison to standard, standard pattern parts or by any other means necessary to ensure compliance.

- 5.1.1 Refer to Appendix 7.2 with regard to the 2026 BRSCC Fiesta Junior Championship Mandatory Parts & Supplier List. ALL parts listed in the relevant section of Appendix 7.2 are Mandatory Fitment, and all MUST only be supplied by appointed championship supplier Racesport Ltd or their appointed representatives.

### 5.2 GENERAL DESCRIPTION

- 5.2.1 The BRSCC Fiesta Junior Championship is for competitors participating in the 3 door Mk7 Ford Fiesta 1.6 Zetec S with 1596cc Sigma engine, manual transmission and Electronic Control Module, modified in accordance with the following regulations.

Vehicles must comply with the current Formulae Junior Technical Requirements and the appropriate Junior Race Vehicle Identity Form and be issued with a Motorsport UK Vehicle Passport, with which it must also comply.

#### 5.2.2 Examination of Vehicles

The Eligibility Scrutineer (in addition to any other powers held under these Regulations) reserves the right before or after any qualifying session or race in the Championship to designate any one or more of the competing cars for special eligibility scrutineering. Competitors must be prepared, with tools and spare parts as necessary, to enable dismantling, removal and inspection of components, or to have any component(s) sealed at the circuit for later inspection by an Eligibility Scrutineer at the competitor's expense.

Upon such election being made the competitor shall immediately place the car under the control of the organisers and be deemed to have permitted all such scrutineering, examination and testing as the organisers may responsibly require to undertake. The organisers, Eligibility Scrutineer and any person appointed by him has the right to:

- A) Examine any aspect of the car at the circuit for such period as they may reasonably require and take fuel and/or other samples and/or
- B) Retain the car or any part for detailed examination at premises chosen by the organisers. If the organisers or the Eligibility Scrutineer elects to retain the car they shall make it available for collection by the competitor at least seven days prior to the qualification session for the next race in the Championship unless the car is found to be in breach of these regulations and/or
- C) Seal the car and its components in accordance with the NCR in such a manner as they may choose and require the competitor at their own expense to present the car at any other premises chosen by the organisers for detailed examination within a specified period and/or remove the car by transporter at cost to the competitor to an appointed location. The competitor will be advised in writing of the time, date and location of the subsequent testing or eligibility examination. Validity of seals fitted to any part of any car by the Eligibility Scrutineer or his appointed assistant, will

remain until permission has been given to remove them by the Eligibility Scrutineer. Unauthorised removal or alteration of seals may result in the car being deemed non-compliant with these regulations. The competitor will be liable to cover all relevant and receipted expenses costs in relation to the required personnel in attendance for any such vehicle inspection, as well as for any costs related to removal, dismantling, refitting of any components as requested as part of the process. The organisers accept no liability for any parts that may be rendered unserviceable due to the inspection process.

The overseen stripping of the engine or any required component will be undertaken by the competitor and/or mechanic/technician nominated by the competitor.

The organisers reserve the right to re-inspect vehicles at any time during the course of the season.

Competitors will be personally and solely responsible for ensuring that their cars comply with their registration details and with these Regulations for each event at which they are entered. Failure to comply in either respect will be a breach of these Regulations. Queries concerning eligibility should be referred in writing to the organisers/championship Eligibility Scrutineer at least seven days prior to an event entered, to permit a ruling in advance of any [event](#) at which it is intended to compete.

Any weighbridge or pad scales used by the organisers at a circuit, which may include that held by the championship organisers, will be considered definitive and the weight of a car established on such a weighbridge will be a finding of fact subject to NCR Ch.10 App.5 Arts.2.3-2.4.

A conversion factor of 0.454 kilos/pound rounded up to the nearest kilo or pound will be used. No other tolerance will be allowed.

5.2.3 It should be clearly understood that the regulations set out in the current NCR apply except where amended by the following texts.

It should also be understood that if it is not clearly specified that you can carry out a modification then you should work on the principle that you cannot.

### 5.3 SAFETY REQUIREMENTS

In addition to the safety requirements of NCR Chapter 7, NCR Chapter 9 and NCR Ch.12 App.12-13, the following criteria will apply.

Maximum driver escape time: Drivers must be able to vacate the car within 7 seconds. Other Safety Requirements are specifically covered below.

#### A) **Roll over protection**

All Cars must be fitted with the roll over protection system (roll cage) designed and homologated by SW Motorsports for the BRSCC Fiesta Junior Championship Mk7 Zetec S cars (Certificate No 21/2611). SW Motorsports are the only authorised ROPS system installer.

A certificate of compliance will be issued after completion of fitment to the car. A copy of the roll cage certificate must be made available to officials on request.

Where the occupants' bodies could come into contact with the safety cage, FIA-approved non-flammable padding must be provided for protection.

In accordance with FIA Appendix J Art 253.8.3.5 and mandatory on all ROPS bars within 500mm of the driver's helmet whilst seated normally, padding complying with FIA standard 8857-2001, type A must be fitted.

Roll cages must only be fitted in accordance with the manufacturer's instructions, and no form of additional welding, bracing or modification is permitted.

**B) Safety Harness**

A 6-point safety harness in accordance with FIA Appendix J Article 253-6 manufactured for use with the FHR System is mandatory. These belts must comply with FIA 8853-2016. Refer to appendix 7.2 for mandatory part details.

(The FHR System must also be used – see below).

**C) Driver's Seat**

The seat must be Homologated to either FIA 8855-1999, FIA 8862-2009 or FIA 8855-2021 and installed in accordance with FIA Appendix J Art 253. 16. Refer to appendix 7.2 for mandatory part and seat mounting plate details. Only on the grounds of safety, the organisers reserve the right to grant a waiver allowing a competitor to use a different seat from the item mandated in the mandatory parts list, provided the alternative seat meets the homologation and installation requirements above. Any such request will be subject to the strict review of the organisers and a Motorsport UK Technical Commissioner. Any request must be submitted to the organisers at least 14 days prior to the first event in which the competitor intends to compete.

**D) Fire Extinguisher**

The only permitted fire extinguishers must be FIA homologated as listed on technical list No. 16 or technical list No. 52 (FIA 8865-2015) and installed in accordance with FIA Appendix J Art 253. Refer to appendix 7.2 for mandatory part details.

**E) Overalls**

Drivers must wear overalls as well as gloves, long underwear, a balaclava, socks and shoes/boots homologated to the FIA 8856-2000 or 8856-2018 standards, as detailed in FIA Appendix L Chapter III Article 2.

**G) Driver's Window Net**

A protective net is compulsory. It must be fitted in accordance with the manufacturer's instructions. Window nets must be fitted in accordance with FIA Regulations Appendix J Art. 253-7.2 – Article 11 (Window Nets). Refer to appendix 7.2 for mandatory part details.

**H) Safety Helmets**

These must be to the standards specified in NCR Ch.9 Arts.5-10 (i.e. be acceptable for International and Motorsport UK events) and must incorporate an FIA approved FHR device fitted in accordance with FIA Regulations. It is highly recommended that the helmet visor be fully closed whilst on circuit.

**I) Racing Nets**

It is highly recommended that Racing Nets homologated according to FIA standard 8863-2013 are fitted to the drivers left side of the car in accordance with manufacturer's instructions.

**J) FIA Impact Data Recorder**

It is mandatory for an FIA Impact Data Recorder (IDR) to be fitted to the vehicle. This must be installed as per the manufacturer's instructions.

5.3.1 A battery cut-off master switch must be installed. The circuit breaker when operated must isolate all electrical circuits with the exception of those that operate the fire extinguishers. NCR Ch.7 App.5 Art.5 and NCR Ch.12 App.13 Art.10 apply.

5.3.1.1 The triggering system for the circuit breaker must be mounted on the supplied bracket and positioned at the base of the passenger side front windscreen. Refer to appendix 7.2 for mandatory part details. The location is to be identified by a RED SPARK on a WHITE EDGED BLUE Triangle and the ON and OFF positions are to be clearly marked.

5.3.2 For scrutineering purposes the bulkhead between the main engine bay and the area occupied by the Interior Heater and Windscreen Wiper unit will be considered as a bulkhead that must be sealed.

External windscreen trim(s) must not be removed.

**5.4 GENERAL TECHNICAL REQUIREMENTS & EXCEPTIONS**

5.4.1 Definitions: All references to standard parts and/or material in these regulations shall be interpreted as references to the manufacturer's original specification(s).

5.4.2 All parts must remain as Standard except for the Modifications Specifically Permitted within these regulations.

5.4.3 Unless specifically authorised in these regulations, the use, substitution of, and/or addition of, any parts, material or processes is prohibited, other than welding or repairing material or the fitting of the manufacturer's standard replacement parts, for the sole purpose in every respect of restoring the vehicle to the manufacturer's Standard specification or to comply with Motorsport UK statutory safety requirements.

**5.5 CHASSIS**

5.5.1 No seam welding of the body shell is permitted. Unless required for the purpose of installing the ROPS, harness plates or repairing damaged areas, no additional welding of the bodyshell is permitted. Any repairs carried out must replicate factory / OE pattern welds as closely as possible. Unless specifically referred to elsewhere in these regulations, it is not permitted to remove any metal from any part of the bodyshell, whether on the exterior or interior of the car. For the avoidance of doubt this includes redundant internal brackets, bonnet bracing, door or tailgate internals and/or any other similar items.

5.5.2 No modifications are allowed which will cause the axis and/or position of the suspension pick-up points on the chassis to be moved.

5.5.3 There must be towing eyes with minimum internal diameter of 60mm securely fixed to the main structure of the vehicle, front and rear, within the confines of the body to enable the vehicle to be moved in accordance with NCR Ch.12 App.13 Arts.1.3-1.4. In respect of the front towing eye, this may not protrude beyond the vertical plane of the front bumper by more than 10mm. For the avoidance of doubt this precludes the use of the standard towing eye in its standard location, competitors must find an alternative.

It is a mandatory requirement that Race Cars should be equipped with two front and two rear towing eyes positioned equally either side of the longitudinal centre line. They should be clearly visible, marked

with an arrow and the word “tow” and coloured yellow, red or orange to contrast with the vehicle colour scheme. Refer to appendix 7.2 for mandatory part details.

The towing eyes should be fixed to a structural part of the chassis with a minimum of M12 fixings, the inner part should be flexible in order for the towing eye to be retracted inside the bodywork profile. A “pull-cord” must be attached to the towing eye to enable the marshals to access the wire loop.

Towing straps or wires must be in good condition and must be replaced if significant damage or wear is evident.

- 5.5.4 Bonnet and tailgate fasteners must be used. Only the items as supplied with the mandatory parts kit must be fitted. Refer to appendix 7.2 for mandatory part details.

The front secondary bonnet catch, must remain **fitted and** operative.

- 5.5.5 Steering lock must be rendered inoperative and may be removed from the vehicle. Cars fitted with Safety Airbag in the steering wheel must have them removed. Caution is required over the removal of any airbag device. If in doubt contact the Eligibility Scrutineer for the correct method of removal.

## 5.6 BODYWORK

### 5.6.1 Modifications Permitted

#### 5.6.1.1 General

Modifications are not permitted other than those explicitly stated below.

#### 5.6.1.2 Interior

5.6.1.2.1 Spare wheel and tools must be removed.

5.6.1.2.2 Alternative steering wheel. Refer to appendix 7.2 for mandatory part details.

5.6.1.2.3 Non-standard driver’s seat. – See Regulation 5.3(c). Refer to appendix 7.2 for mandatory part details.

5.6.1.2.4 Removal of floor carpeting and **all** sound deadening.

5.6.1.2.5 Removal/replacement of passenger seats.

5.6.1.2.6 Removal of passenger compartment heater and heater controls is not permitted. Ducting and pipework may be removed or rerouted behind the dashboard, however the system must be able to demonstrate windscreen demisting.

5.6.1.2.7 Fuel and brake lines may be routed through the driver/passenger compartment subject to provisions of NCR Ch.7 App.1 Art.18 and NCR Ch.7 App.4 Art.5. **Drilling of holes to enable brake and fuel lines to enter and exit the passenger compartment is permitted, but no additional metal may be removed.** It is permitted to cover fuel lines to protect from heat.

5.6.1.2.8 It is not permitted to remove the rear seat mountings or any other fixed internal metal or bracketry, apart from the removal of metal to allow access to the fuel pump from inside the passenger cabin. Should this option be chosen, the hole must be fully covered by the fuel pump cover panel as supplied by Racesport Ltd or their appointed representatives, and as per the following picture.



5.6.1.2.9 The gear knob may be replaced.

5.6.1.2.10 Central locking and alarm system must be rendered inoperative by the removal of the fuse or that wiring element.

5.6.1.2.11 The inside of the driver's door must be filled with energy absorbing material. Material type: IMPAX 300 type (nominal density 37kg/m<sup>3</sup>). ([Refer to appendix 7.2 for mandatory part details](#))

The only permitted side protection panel is the item supplied by Racesport Ltd or their appointed representatives as part of the mandatory ROPS, and this must be fixed to the roll cage by way of the homologated fitting tags. (Refer to appendix 7.2 for mandatory part details) This part complies with Drawing 255-14.

Vertically, it must extend from the bottom of the door to the maximum height of the safety cage door bars. Horizontally, it must extend at least from the front rollbar to the driver's seat back.

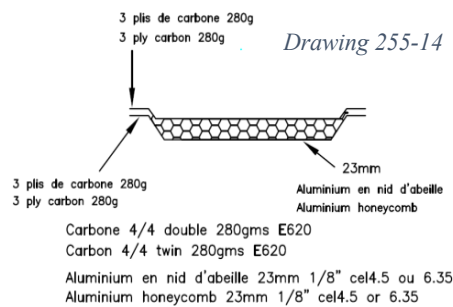

### 5.6.1.3 Exterior

5.6.1.3.1 It is permitted to use additional fixings/tethers to retain items of trim into the front and rear bumpers.

5.6.1.3.2 Both door mirrors must be of the standard mirror and housing shape for the model being raced and must conform with regulations related to the silhouette.

5.6.1.3.3 All side windows must be those specified in appendix 7.2 and fitted as per the manufacturer's instructions. Refer to appendix 7.2 for mandatory part details. Front windscreen and rear tailgate screen must remain as standard fitment.

Front door quarter light glass may be replaced by clear plastic / polycarbonate versions with a minimum thickness of 4mm.

5.6.1.3.4 The addition of small external bracing plates or ties between the edges of the plastic bumpers and metal bodywork is permitted.

5.6.1.3.5 OEM plastic inner wheel arch liners may be retained, removed or trimmed.

#### 5.6.1.4 Silhouette

All body panels along with the front and rear bumpers and lights must only be those as fitted to UK specification 3 door Mk7 1.6 Fiesta Zetec S models. For the avoidance of doubt, it is not permitted to fit panels, bumpers or lights from later models.

Fitment of championship control rear aero wing and front splitter is mandatory. Refer to appendix 7.2 for mandatory part details. Rear wiper motor, wiper arm and blade may be removed.

#### 5.6.1.5 Ground Clearance

Minimum ground clearance is 110mm with driver (with full racing kit) aboard, which will be measured from the lowest point of the front subframe (rear) retaining bolt as shown in Image 1. This bolt must remain as standard OEM and must retain the original 5mm washer, as shown in Images 2 and 3. Measurement will be taken from either side of the car.



#### 5.6.2 Modifications Prohibited

##### 5.6.2.1 General

Modifications are not permitted other than those explicitly stated in 5.6.1.

##### 5.6.2.2 Interior Trim and Instruments

5.6.2.2.1 Standard interior door trims must be replaced by those supplied by Racesport Ltd or their appointed representatives. Refer to appendix 7.2 for mandatory part details.

Standard dash panels and instruments must be fitted and MUST be complete with all switches, steering controls, steering column cowl. The body of the radio can be removed, however all standard controls, air vents and switchgear must remain fitted in the central part of the dashboard (as per Image A). Standard centre console complete with standard handbrake lever and handbrake surround must remain fitted. Glove box internals may be removed, however glovebox lid must remain fitted.

Image A



It is a mandatory requirement to locate internal fire extinguisher and electrical cut off controls in the panel as supplied by Racesport Ltd or their appointed representatives. Refer to appendix 7.2 for mandatory part details.

5.6.2.2.2 Interior mirror must be fitted and is free.

### 5.6.2.3 Exterior

Front windscreen and rear tailgate screen must remain as standard fitment. See 5.6.1.3.3 for side windows.

## 5.7 ENGINES

### 5.7.1 Permitted Modifications

The only permitted engine is the Sigma engine as fitted to UK supplied Mk7 Fiesta 1.6 Zetec S models. All [championship specification](#) engines must be supplied directly from the appointed championship suppliers Racesport Ltd or their appointed representatives. Engines supplied by Racesport Ltd or their appointed representatives will be rebuilt to a championship controlled standard and specification. All engines will be sealed with Motorsport UK compliant tamper proof seals prior to fitment to the car. All seals will be recorded by the championship Eligibility Scrutineer and a record will be kept of which engine is fitted to each car. Without authorisation having been granted by the championship Eligibility Scrutineer, the removal, breaking of, or tampering with these seals will render the car as non-compliant with championship regulations. Removal of seals for any purpose can only be authorised in advance by the championship Eligibility Scrutineer. Refer to appendix 7.2 for mandatory part details.

### General

No modifications to the specification, or other variant of the engines are permitted except for changes specifically detailed in these regulations. The engine blow by gases must be fed into a catch tank with a containable minimum internal volume of 2 litres. All production openings into or out of the engine not used as a direct result of this change must be effectively sealed.

The term standard shall apply to that as manufactured by the Ford Motor Company and will include the tolerances as manufactured by Ford Motor Company. If you are in any doubt then consult the Eligibility Scrutineer. Due to part availability, pistons and bearings may be substituted with OEM matching quality parts to exactly the same specification as the original Ford part, but only when supplied and fitted by

5.7.1.1 All standard production engine sensors which have any influence whatsoever on the engine management system must be retained in the correct position and in working order. It is not permitted to reposition positional sensors.

5.7.1.2 The designated engine Electronic Control Unit (ECU) or any of its associated parts shall not be modified in any way. It is not permitted to change the strength or form of any of the sensor signals to or from the ECU or ignition amplifier unit. The organisers reserve the right to require any competitor to surrender the ECU fitted to the competition vehicle for eligibility testing. Failure to obey any request will be deemed to contravene these regulations.

5.7.1.3 All cars must have the 2026 Championship Control ECU software installed. This software shall be regarded as the only software permitted to be installed and used. Please refer to appendix 7.2 for mandatory part details.

5.7.1.4 The choice of make and type of spark plugs is free, but must be equivalent to the standard OEM parts.

5.7.1.5 Where fitted, air conditioning pump, condenser and all related pipework can be removed. It is permitted to fit a shorter drive belt and alternative pulley as required.

#### 5.7.1.6 **Air filter**

Mandatory control air intake kit as supplied by Racesport Ltd or their appointed representatives must be fitted. Refer to appendix 7.2 for mandatory part details.

#### 5.7.2 **Prohibited Modifications**

5.7.2.1 Polishing or reworking of any part(s) including the inlet and exhaust manifolds, the inlet and exhaust tracts and combustion chamber space in the cylinder head.

5.7.2.2 Standard OEM fuel injectors for the model of car being raced must be fitted. It is not permitted by any means to alter fuel delivery pressure away from OEM standard for the car being raced.

#### 5.7.3 **Location**

The engine must remain in the 'as manufactured' location in terms of lateral/longitudinal/vertical axis.

#### 5.7.4 **Oil/Water Cooling**

Engine water pipes may be changed to silicone based hose to same size and dimension, hoses may be covered to protect from heat.

The mandatory control radiator as supplied by Racesport Ltd or their appointed representatives must be fitted. Refer to appendix 7.2 for mandatory part details.

It is permitted to fit an aftermarket coolant temperature gauge and/or warning lamp. To achieve this, the unit may be wired as necessary to facilitate functionality.

#### 5.7.5 **Induction Systems**

No modifications to the throttle body or manifolds are permitted.

### 5.7.6 Exhaust Systems

5.7.6.1 The complete exhaust system including the exhaust manifold and catalytic convertor must only be the mandatory control item as supplied by Racesport Ltd or their appointed representatives. Refer to appendix 7.2 for mandatory part details. Catalytic convertor operation may be tested by any means.

5.7.6.2 The front O2 / Lambda sensor must remain fitted and fully operational, with no spacers or emulators permitted. The secondary / rear sensor may remain disconnected, or may be fitted by way of welding a lambda “boss” into the exhaust. If choosing that option, the boss must be positioned to the rear of the catalytic convertor, and 500mm +/- 30mm from the front flange of the centre pipe. Extending the secondary lambda sensor wires is permitted.

5.7.6.3 The section of exhaust show in the image below may be covered in protective heat wrap to reduce heat transfer where the system is close to the fuel tank. The heat wrap must be removable to allow inspection of the part by an Eligibility Scrutineer. No other part of the manifold or exhaust system may be heat wrapped or coated.



### 5.7.7 Ignition Systems

The ‘as manufactured’ ignition and engine management control unit must be used. All modules may be sealed by the organisers and numbered and recorded.

ECU seal as per photograph ECU01



Photograph ECU01

The organiser reserves the right to download software directly onto any competitor’s ECU. This software must not be tampered with or altered in any way. A nominal charge for this software will be borne by the competitor.

The organisers retain the right to provide a replacement ECU at any time during any Event.

## 5.8 SUSPENSIONS

### 5.8.1 Permitted Modifications

5.8.1.1 The only shock absorbers, spring set and suspension bush set up permitted for use, is the full championship control AST Suspension kit and Powerflex Bush kit as supplied by Racesport Ltd or their appointed representatives. Refer to appendix 7.2 for mandatory part details.

To allow correct fitment of the front suspension units, the top FRONT strut turret centre hole on both sides must be opened up to a MAXIMUM diameter of 70mm. The enlarged hole must remain centred and must not be offset from the original position. The 3 x top plate mounting bolt holes must not be modified in any way. Refer to the following images:

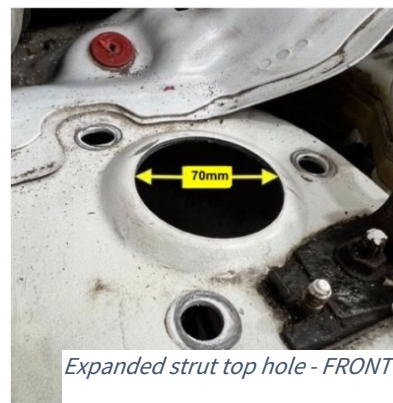

To allow correct fitment of the rear suspension units, the top REAR strut turret centre hole on both sides must be opened up to a MAXIMUM diameter of 42mm. The enlarged hole must remain centred and must not be offset from the original position. The strengthening plate and 2 x original bolt holes must not be modified in any way. Refer to the following image [for guidance on what may be removed](#):



5.8.1.2 At any time of their choosing, the Championship Eligibility Scrutineer may request the removal of any front or rear AST suspension unit for compliance testing by an AST technical agent. The Scrutineer will provide a Championship compliant replacement unit which may remain fitted to the car until the original

unit has been returned. The competitor will be responsible for the cost for repair or renewal of the replacement unit should it be damaged whilst fitted.

5.8.1.3 Front suspension wishbones must be OEM or standard pattern parts which are specified for fitment to the Mk7 Fiesta 1.6 Zetec S. It is permitted to secure the front wishbone rear bush by way of the following image.



## 5.8.2 Prohibited Modifications

No modifications may be made directly to the rear axle beam or front subframe. This includes welding, bending, cutting, strengthening, modifying or reshaping in any way. No alterations may be made to the front wishbones and mountings for any reason, including to alter caster or camber. The Mk7 Fiesta 1.6 Zetec S standard front anti-roll bar must be fitted and operational, and this must be a maximum/minimum thickness of 22mm +/- 0.5mm when measured from the area directly under the anti-roll bar front bushes.

It is not permitted to modify the front suspension stub axles in any way. No modifications to component mountings permitted.

5.8.2.1 Up to 4 shims, each with a maximum total thickness of 5mm may be used between the stub and the axle beam to achieve adjustment of camber and toe. For the avoidance of doubt, even if using multiple shims, the maximum total combined shim thickness permitted for each mounting hole is 5mm.

5.8.2.2 It is not permitted to alter the internal specification of any AST shock absorber from that as supplied by the manufacturer.

## 5.8.3 Wheelbase / Track

As standard or as amended by permitted alterations.

## 5.9 TRANSMISSIONS

### 5.9.1 Permitted Modifications

The only permitted gearboxes and differentials are standard unmodified units fitted as standard to UK specification 3 door Mk7 Fiesta 1.6 Zetec S models.

The only permitted gearbox and final drive ratios are as per the below table. No other combination of gearbox gears or ratios are permitted.

	<b>Input Shaft Gear Teeth</b>	<b>Output Shaft Gear Teeth</b>	<b>Ratio</b>
1st	12	43	3.583
2nd	26	53	2.038
3rd	29	41	1.413
4th	37	41	1.108
5th	41	36	0.878
<b>Final Drive Teeth</b>	<b>Crownwheel</b>	<b>Pinion</b>	<b>Ratio</b>
	65	17	3.82

Minimum flywheel weight including ring gear and without flywheel bolts is 7.5kg (with no tolerance). This minimum weight allows for the flywheel clutch plate face to be resurfaced in the event of damage or wear. The clutch plate face of the flywheel is the ONLY area where machining is permitted, and only as a means of recovering the clutch plate contact surface.

## 5.9.2 Prohibited Modifications

It is not permitted to modify gearbox or final drive internals, this includes superfinishing, shot peening and any other such like processes. The standard OEM differential must be fitted, and no form of limited slip differentials are permitted. The flywheel and clutch cover must remain as standard / standard pattern.

Other than Art 5.9.1, no modification of the standard flywheel is permitted, this includes any form of balancing or lightening.

No alterations to the standard gearchange system are permitted.

## 5.9.3 Transmission and drive ratios

Only Ford production parts are allowed. Art 5.9.1 applies.

5.9.3.1 The clutch pressure plate may be replaced by an aftermarket item, but it must be the same size, weight and dimension as the standard item. An aftermarket clutch friction plate may be fitted, including paddle type design, but the standard clutch pressure plate and release bearing along with all other standard clutch related parts must remain fitted.

5.9.3.2 Hub bearings must be of a standard type as available from the manufacturer's agent or motor factors. No form of superfinishing or specialist bearing treatments is permitted.

## 5.10 ELECTRICS

### 5.10.1 Exterior Lighting

Apart from front fog lamps which must be removed, all lights must be in full working order with the exception of the rear number plate light and the side repeater flashers which must be present but can be non-functional.

### 5.10.2 **Rear Rain / Bad Weather Light**

The rear facing rain light and fitting bracket as supplied by Racesport Ltd or their appointed representatives must be fitted. Refer to appendix 7.2 for mandatory part details. Rain Light Switch must be installed to operate the rear rain light and must be positioned so it can be operated by the driver in their seated position. This switch must provide the driver the ability to turn on the rain light in poor visibility conditions (see NCR Ch.7 App.5. Art.6.4.

### 5.10.3 **Batteries**

A 12 volt battery must be used and fitted securely. Dry cell or Gel type batteries are recommended. The battery top must be covered by an insulating cover to prevent short circuits in the case of an accident.

The battery must remain in its original under-bonnet location, however it may be secured by additional or modified securing brackets. [Racesport Ltd can supply modified battery securing bracketry.](#)

### 5.10.4 **Generators**

The standard unmodified alternator must be fitted and operational at all times.

### 5.10.5 **Wiring harness**

The main wiring harness cannot be modified except as required for the fitting of the battery master switch. NCR Ch.7 App.5 Art.5. No data logging equipment may be connected into the ECU either by direct or indirect means.

The fuse box, ECU, OBD diagnostic plug and all other electrical units must remain located in their standard original positions.

5.10.6 All cars may have a system of lamp indication to determine engine revolutions to indicate gearchange point (Shift Light) or an LED display to give the gear in which the car is currently being driven (Digital Gear Indicator). To achieve this, the unit may be wired into the instrument loom to facilitate the functionality of either unit.

## 5.11 **BRAKES**

### 5.11.1 **Permitted Modifications**

5.11.1.1 The only permitted front brake pads and brake discs, as well as the braided brake hoses are the items supplied by Racesport Ltd or their appointed representatives. Refer to appendix 7.2 for mandatory part details.

Standard or standard pattern Mk7 Fiesta 1.6 Zetec S brake calipers, drums, shoes, wheel cylinders, cables, master cylinders, pedal box, and unless otherwise stated all other standard hydraulic or electronic braking parts must be fitted, and all must operate as per the standard braking system.

ABS as fitted must remain as standard and must retain the functionality to operate as standard, however may be disabled by the removal of relevant fuses. Electronic Stability Program (ESP) and Traction Control System (TCS) may be disabled. Anti-slip or extension pads may be added to all foot control pedals.

[The handbrake in terms of fitment and operation must remain as standard, however it is recommended that the ratchet mechanism in the handbrake lever is removed or disabled.](#)

5.11.1.2 Brake ducting can be installed for the front brakes using the front fog light position in the front bumper as an entry point. Mounting of the ducting will be behind the bumper. The standard [fog lamp](#) bezels must be retained in the standard position.

#### 5.11.2 Prohibited Modifications

No further modifications permitted.

### 5.12 WHEELS/STEERING

#### 5.12.1 Permitted Options

Braid wheel 7 x 15 Fullrace Maxlight or Fullrace C - Offset 35mm. Refer to appendix 7.2 for mandatory part details.

A standard, and unmodified Power Assist Steering (PAS) steering rack must be retained, fitted and operational at all times. The mounting bushes for the steering rack shall be the standard bushes. Steering wheel and fitting boss: Refer to appendix 7.2 for mandatory part details.

#### 5.12.2 Prohibited Options

No other item is permitted.

### 5.13 TYRES

#### 5.13.1 Specification

Dunlop control tyres identified by individual coding and logo.

Dry - Dunlop 195/50R15 DZ03G R3

Wet – Dunlop 637703 - 180/580R15 GY WET-L-TC02W3 [or 640958 - 180/580R15 GY WET-L-TC03W3](#)

Wet – Dunlop 637704 - 180/580R15 GY WET-R-TC02W3 [or 640959 - 180/580R15 GY WET-R-TC03W3](#)

The organisers reserve the right to introduce a different control tyre in the following season year.

#### 5.13.2 Nominated Supplier

The control tyre supplier is:

Mr Tyre (Motorsport) Ltd  
Unit 1 Apex Centre  
Lovell  
Tamworth  
B79 7TA  
Tel: 01827 211021

#### 5.13.3 [Tyre Condition and Modification](#)

[a\) Tyre shaving, cutting, re-profiling, grinding, buffing, chemical treatment, heat treatment, or any other process intended to alter the tread depth, profile, construction, or performance characteristics of the tyre is strictly prohibited.](#)

b) All the manufacturers' data must be clearly visible. Buffing or scrubbing of sidewalls to remove data is prohibited.

c) Any tyre(s) which, in the opinion of the Eligibility Scrutineer, appears to have been shaved or otherwise modified may be impounded immediately for further examination.

d) Impounded tyres may be submitted for inspection and analysis to:

- the Championship's nominated tyre supplier, and/or
- the tyre manufacturer or their appointed agent, and/or
- any independent tyre industry professional as chosen by the Organisers.

e) The burden of proof that a tyre complies with these regulations rests with the Competitor at all times.

f) Any breach of this regulation shall be deemed a technical infringement and may be penalised in accordance with:

- the Championship Regulations,
- the Motorsport UK National Competition Rules, and
- the Judicial procedures therein, and may result in penalties up to and including disqualification from the session, event, or Championship.

At the start of each qualifying session or race, all tyres must have a minimum of 1.6mm tread depth remaining across at least the central  $\frac{3}{4}$  tread area of the tyre, and around its full circumference. The Eligibility Scrutineer (or their appointed deputy) reserves the right to inspect, take tread depth measurements, photograph or impound any tyre they believe to be non-compliant with the above description whilst the car is in the pre-session assembly area, and to advise the driver that they are not permitted to enter the circuit due to the car being considered non-compliant with these regulations.

Post-session, and whilst any car is under parc ferme conditions, the Eligibility Scrutineer (or their appointed deputy) reserves the right to inspect, photograph or impound any tyre they believe to be non-compliant with these regulations. As well as tyres being impounded as the eligibility Scrutineer chooses, a non-compliance report will be issued.

Should any driver wish to have the compliance of any tyre confirmed ahead of taking part in an official session, they must request that their tyres are inspected by the Eligibility Scrutineer BEFORE taking their car onto the circuit.

5.13.4 Unless otherwise instructed by the clerk of the course at the event, it shall be the sole responsibility of the competitor to judge whether the track is wet enough to justify the use of wet weather tyres.

#### 5.13.5 Tyre Nomination

5.13.5.1 The maximum number of Dunlop 195/50R15 DZ03G tyres available to each competitor will be limited to a total of 6 tyres per event.

Only Dunlop 195/50R15 DZ03G tyres nominated for the event listed on the tyre nomination system, and "wet weather" tyres (see 5.13.1), will be permitted to be used at each event between the start of the first free-practice/qualifying session and the end of the final race of the event. This includes tyres being carried in the pit lane, in the assembly area, and in Parc Fermé.

5.13.5.1.1 An additional 2 dry tyres may be permitted, however only if the technical representative from Goodyear and/or the Championship Eligibility Scrutineer agree that this is necessary for the event concerned. In that instance, the organisers will notify all competitors by event bulletin.

5.13.5.2 For the first event of the season, each competitor will be permitted to nominate a maximum of 6 Dunlop 195/50R15 DZ03G tyres. These can be new or previously used tyres.

For each subsequent event, each competitor will be permitted to nominate a maximum of 2 new Dunlop 195/50R15 DZ03G tyres, within their maximum allocation of 6 tyres. The balance of the allocation must be previously nominated tyres. All 6 tyres may be those which have been previously nominated.

5.13.5.3 In the case of a competitor joining the championship after the first event, they will be permitted to nominate a maximum of 4 new Dunlop 195/50R15 DZ03G tyres at their first event of the season, within a maximum allocation of 6 tyres. All 6 tyres may be previously used tyres. Any previously used tyres must be presented to the Championship Eligibility Scrutineer for inspection before they are permitted for use in any free practice, qualifying or race session.

5.13.5.4 Each competitor must record on the Tyre Nomination system the serial numbers of the 6 tyres Dunlop 195/50R15 DZ03G tyres which they intend to use at each event.

The Tyre Nomination system submission must be submitted to the Licenced Eligibility Scrutineer before the first Qualifying session of each event. The Licenced Eligibility Scrutineer or his appointed representative will retain copies of the submitted information. The onus is on the competitor to ensure that the completed information is deposited with the Licenced Eligibility Scrutineer or appointed representative before the first official qualifying session. Failure to do so will be the subject of a report to the Clerk of the Course/Stewards.

Should for any reason the official Tyre Nomination system be inoperative, it is the responsibility of each competitor to manually nominate their tyres directly to the Championship Eligibility Scrutineer or their appointed representative before the first official qualifying session.

5.13.5.5 Only in exceptional cases where in the judgement of the Licenced Eligibility Scrutineer damage to a maximum of 2 nominated tyres makes further participation in the event impossible, previously nominated tyres may be substituted. The substitution may only be authorised by the Licenced Eligibility Scrutineer.

5.13.5.6 Only in very exceptional cases, and at the discretion of the championship co-ordinator, where, in the judgement of the Licenced Eligibility Scrutineer, damage to tyres makes further participation in the event impossible, and all previously nominated tyres are not usable, additional new Dunlop 195/50R15 DZ03G tyres above the maximum permitted allocation may be permitted. However for every additional tyre above the maximum allocation, the competitor will incur a 10 Championship point deduction. It is the competitor's responsibility to notify the Licenced Eligibility Scrutineer AND Championship Co-Ordinator of their intention to exceed the tyre allocation prior to any Qualifying sessions or races.

5.13.5.7 At the Licenced Eligibility Scrutineer's discretion any of the 6 Dunlop 195/50R15 DZ03G tyres for the event listed on the Tyre Nomination system may be retained at the end of any Qualifying session or Race, until a minimum of 30 minutes prior to next time that the tyres are required to be used.

5.13.5.8 The number of Dunlop wet weather tyres permitted for use by each competitor is not restricted.

5.13.5.9 It is not permitted to mix tyre specifications, cars must be fitted with either 4 x Dunlop 195/50R15 DZ03G dry tyres or 4 x Dunlop wet tyres during all official free practice, qualifying and race sessions.

**5.14 VEHICLE WEIGHT****5.14.1 Definition**

As per NCR Ch.7 App.2 Art.19.

**5.14.2 Minimum Weights**

The minimum all-up weight, including the driver in full racing kit, at any time during an event is 1075kg. For the purposes of the Regulation, an event is deemed to include any transfer to a place of post-event scrutiny as directed by an official. If ballast is carried it must be identified to the scrutineer at pre-event inspection, and be capable of being sealed in position if required. Ballast can only be installed in the position as per NCR Ch.7 App.2 Art.19(or as amended).

**5.15 FUEL TANK AND FUEL****5.15.1 Types**

Standard production fuel tank must be retained. Additionally, all of its exposed surfaces under the car, except those in contact with the bodyshell, must be protected. [Refer to appendix 7.2 for mandatory part details.](#)

5.15.1.1 It is permitted to fit a dry break / fuel drain coupling. This must be positioned in the engine bay and away from heat sources such as exhaust manifolds.

**5.15.2 Location**

The tank must be retained in its standard position.

**5.15.3 Fuel**

Only Permitted Fuel as defined by NCR Ch.8 App.1 Art.1.7.a complying with BSEN228 may be used. [The use of power boosting or octane boosting additives by competitors in any fuel is prohibited. A minimum of 3 litres of fuel must remain in the fuel tank at the end of qualifying or race.](#)

**5.16 SILENCING****5.16.1 Specification**

Vehicles must be silenced in accordance with NCR Ch.7 App.8.

**5.17 COMPETITION NUMBERS/DECALS**

5.17.1 Positions: Competition numbers must be displayed in accordance with NCR Ch.12 App.4 Arts. 5.6-5.8.

The numbers for each rear side window, shall be:

- (1) a minimum of 200mm high
- (2) with a stroke width of at least 20mm
- (3) coloured fluorescent yellow

In addition, the windscreen of all cars must display the competition number positioned on the upper side area of the passenger's side of the windscreen, as follows

- (4) the numerals must be at least 150mm high
- (5) be in the same colour and font as those displayed on the rear side windows
- (6) be placed no closer than 50mm from the lower edge of the windscreen “sun strip” and 50mm from the side edge of the windscreen

5.17.1.1 In addition decals of the Championship sponsors, and the BRSCC will be required to be displayed correctly and as per the 2026 Fiesta Junior Livery Plan which can be viewed and downloaded from <https://brscc.co.uk/formulae/fiesta-junior-championship/>.

5.17.1.2 All decals shall be fitted as issued. They may not be cut or otherwise defaced or deformed unless the Championship Co-ordinator has given written permission to do so. Such written permission must be available for inspection during any **Event**. A ‘windscreen strip’ must be affixed to the uppermost part of the front windscreen (see livery plan).

#### 5.17.2 **Suppliers**

BRSCC. One complete set will be supplied to each competitor at the beginning of the season. Charges may be made for replacements.

#### 5.17.3 **Placement of decals**

BRSCC decals will be placed one either side on the area between the top of the front wheel arch and the door.

The championship windscreen decal will be placed to the topmost part of the screen. No other decals are to be placed on the windscreen without championship approval.

**6. APPENDICES**

The following Commercial Undertakings are not subject to the Judicial Procedures of either the Championship Stewards and/or the National Court.

**6.1 RACE ORGANISING CLUBS & CONTACTS****ORGANISING CLUB**

British Racing & Sports Car Club  
 Unit 25 Wheatley Business Centre  
 Old London Road  
 Wheatley  
 Oxford  
 OX33 1XW  
 Tel: 01732 780100  
 www.brsc.co.uk

**TYRES**

Mr Tyre (Motorsport) Ltd  
 Unit 1 Apex Centre  
 Lovell  
 Tamworth  
 B79 7TA  
 Tel: 01827 211021

**6.2 COMMERCIAL UNDERTAKINGS**

6.2.1 Deleted.

**6.2.2 Advertising/Glass**

- A) All glass areas must remain clear and unobstructed by decals/advertising or any other obstruction unless these regulations specify different or approved by the organisers.
- B) The only exception being the rear side windows that should have the drivers' surname, clearly displayed in simple bold type, unless these championship regulations specify a different option.

**6.2.3 Vehicle Presentations**

The presentation of the car is fundamental to the profile of the championship/series its sponsors and its audience. Therefore in considering whether to permit any car to race, and any point during the season, the organisers will regard as paramount the presentation of the car. In taking into account its appearance inherent in which is the standard of its presentation (including interior) they may exclude any car which they consider may prejudice the reputation of the championship/series or is otherwise unacceptable. This will include where the car is presented at a race event bearing accident damage sustained at a previous event and which has not been subject to the completion of a full and proper repair. Note: A double header can be regarded as one event for the purposes of this regulation.

**6.2.4 Vehicle Decals and Overalls**

Competitor's overalls to be clean and maintained to a reasonable standard, and cars deemed to be of an unacceptable standard of presentation may not be permitted to race.

**6.2.5 Promotional Activities**

Competitors may be asked and will be expected to participate in championship promotion activities at the circuits, as requested by the organisers.

**6.2.6 Paddock**

Priority parking to race vehicles and race preparation units only. Road cars and campers permissible by prior arrangement with the organisers only. Request in advance for location of additional parking area.

**6.3 Deleted**

**6.4 Deleted**

7. REGULATORY APPENDICES

The following appendices form part of these regulations where referred to in this document and are subject to the Judicial Procedures at an event or of either the Championship Stewards and/or the National Court.

7.1 Deleted

7.2 MANDATORY & OPTIONAL PARTS LIST

The following list can also be viewed and downloaded by visiting the TECH DOCUMENTS web page at <https://brscc.co.uk/formulae/fiesta-junior-championship/>.

BRSCC Fiesta Junior Championship - Mk7 1.6 ZETEC S: Mandatory Championship Parts List - 2026 Season				
Please Note: ALL of the parts listed below are MANDATORY FITMENT, and must ONLY be purchased and supplied from Racesport Ltd. Fitment of Mandatory Parts not supplied by Racesport Ltd may render the car as Non-compliant with Championship Regulations. To order build kits and spares contact Racesport Ltd here: <a href="mailto:info@racesport.co.uk">info@racesport.co.uk</a> / Tel: 01869 221 600				
SKU	Brand	Product Name	Type	Description
CSFFCIC2	Racesport	Fully rebuilt 1.6 Zetec Engine	Performance	Exchange sealed championship specification engine, re-built using Genuine Ford Components. Suitable donor engines must be supplied by customers first. Please note: The rebuilt engine returned is unlikely to be the same unit as supplied by the customer. Cylinder head will be completely rebuilt to factory specification. The head, block bore and stroke will be measured ensuring OE specification is retained. Compression will be maintained on skimmed heads by way of a repair gasket. Piston rings, valves, all bearings and relevant bolts will be replaced, along with new oil pump and water pump, a full timing set and all new gaskets and seals. The engines will be sealed with individually numbered and recorded tamperproof tags. Should your donor engine be deemed unfit for refurbishment (rod failure, damage to cams, block, crank, pistons etc) a replacement will be requested and a surcharge may be levied.
				Exchange sealed championship specification engine, all re-built to a fixed specification using OEM and carefully selected components. Suitable donor engines must be supplied by customers first. Please note: The rebuilt engine returned may not be the same unit as supplied by the customer. Cylinder head will be refaced and completely rebuilt to factory specification. The head, block bore, stroke and compression will be measured ensuring championship specification are met. Piston rings, valves, all bearings and relevant bolts will be replaced, along with new oil pump and water pump, a full timing set and all new gaskets and seals. The engines will be sealed with individually numbered and recorded tamperproof tags. Should your donor engine be deemed unfit for refurbishment (rod failure, damage to cams, block, crank, pistons etc) a replacement will be requested and a surcharge may be levied. Race engines returned for rebuild or refresh will be inspected and returned to championship specification.
CSFFCIC7	Racesport	Full System Race Exhaust	Performance	Racesport Championship specification 60mm diameter stainless steel full exhaust system, including exhaust manifold and catalytic convertor.
CSFFCIC8	Racesport	Induction Kit	Performance	Racesport induction kit. Includes silicone induction pipe, performance air filter and metal formed heat shield.
CSFFCIC28	Racesport	ECU Map	Performance	Championship specification ECU map by Racesport. Customer supplied ECU's are upgraded with the championship specification map and returned.
CSFFCIC38	Airtec	Radiator	Performance	Lightweight Aluminium large capacity radiator in championship specification (for advanced cooling).
CSFFCIC29	SW Motorsports	Full Junior Spec Rollcage	Interior	Weld in SW Motorsports Cage As FIA Appendix J Art 253.8 and homologated in accordance with FIA ROPS homologation requirements. This is supplied as part of the build kit and must be fitted by SW Motorsports in accordance to homologation rules. Also comes with vehicle chassis plaque to record the build.
CSFFCIC27	Racesport	Drivers Door Impact Insert	Interior	FIA Junior Championship compliant Energy absorbing IMPAX 300 door impact material.
CSFFCIC30	SW Motorsports	Roll Cage Side Protection Panel	Interior	FIA Junior Championship compliant Carbon composite roll cage side impact protection panel
CSFFCIC1	Racesport	Roll Cage Padding	Interior	Roll cage padding. In accordance with FIA Appendix J Art 253. 8.3.5
CSFFCIC32	SW Motorsports	Door Cards	Interior	Door cards / covers for driver and passenger doors.
CSFFCIC33	SW Motorsports	Door Card Pull Kit	Interior	Door pull kit for driver and passenger doors.
CSFFCIC34	SW Motorsports	Heel Plate	Interior	Pre-shaped Heel plate for drivers floor
CSFFCIC35	SW Motorsports	Seat Base	Interior	Mandatory drivers seat base for Racesport Corbeau revenge seat.
CSFFCIC9	Corbeau	Seat	Interior	Cooksport Branded Corbeau Revenge X seat FIA 8855-1999 Homologated.
CSFFCIC10	Corbeau	Seat Side Mounts	Interior	Corbeau side mounts set for single Corbeau revenge seat.
CSFFCIC11	Corbeau	6 Point Harness	Interior	Black Racesport branded 6 point HANS harness Homologated to FIA 8853-2016
CSFFCIC12	Corbeau	Window Net	Interior	Corbeau velcro window net, does not require welding, fits to roll cage.
CSFFCIC14	PD Extinguishers	4ltr Mechanical Extinguisher kit	Interior	PD extinguishers 4.25 Litre AFFF Mechanical Fire Extinguisher System. Supplied in kit form and comes complete with 4.25 litre tank, pull cords, fittings and pipework to install. FIA Homologated EX056-19 Motorsport UK Compliant.
CSFFCIC23	Cartek	Isolator Kit	Interior	Cartek battery isolator kit
CSFFCIC36	OMP	Steering Wheel	Interior	OMP Targa Steering Wheel
CSFFCIC37	Momo	Steering Boss	Interior	Steering wheel boss to enable the fitment of OMP Targa Steering wheel.
CSFFCIC15	ACW Motorsport Plastics	Window Kit x4	Exterior	ACW Motorsport plastics Polycarbonate hard coat 4mm side window kit. Flat front windows and thermoformed rear windows. 4 pieces
CSFFCIC17	Racesport	Front Splitter	Exterior	Championship specific FRP front splitter, pre drilled for ease of location.
CSFFCIC18	Racesport	Rear Spoiler including mounting brackets	Exterior	Championship specific FRP high level rear wing, Aluminium brackets, side plates and fitting kit.
CSFFCIC20	Racesport	Fuel Tank Cover	Exterior	Motorsport UK compliant fuel tank cover. Honeycomb sandwich structure based on a fire-resistant core with a minimum crushing strength on 18N/cm2.
CSFFCIC21	Racesport	Tailgate pins	Exterior	Tailgate fixing system
CSFFCIC22	Racesport	Bonnet Pins	Exterior	Bonnet fixing system
CSFFCIC24	Cartek	Rain Light	Exterior	Cartek rain light
CSFFCIC25	TRS	Tow Loops x4	Exterior	4x steel tow loops
CSFFCIC41	Racesport	Assorted Brackets	Exterior	These include rain light brackets, pull cord brackets, plates for tailgate mounting and other assorted bracketry throughout the car.
CSFFCIC13	Racesport	Decal Sheet	Exterior	Safety decal sheet Inc. tow stickers and arrows, internal and external battery cut off, internal and external fire extinguisher.
CSFFCIC5	AST Suspension	AST5100 kit	Chassis	Complete set of AST 5100 inverted adjustable suspension kit. Camber adjustable front top mounts, ride height adjustable front and rear, single adjust knob. Championship specification springs included. These are built to order, single dampers and external spare parts are available on request.
CSFFCIC15RIM	Braid	Wheels	Chassis	Braid 15x7 et 35 Maxlight or Fullrace C wheel in white, championship marked.
CSFFCIC16	Racesport	Wheel Stud and Nut Conversion	Chassis	16 x extended wheel studs and associated nuts
CSFFCIC19	Powerflex	Polybush Kit	Chassis	Powerflex complete polybush kit. Engine and gearbox mounts, rear beam and front wishbone bushes included.
CSFFCIC3	Mintex	Discs Pair	Braking	Front axle set
CSFFCIC4	Mintex	Front Race Pads Pair	Braking	Mintex Race Brake pads are supplied as pairs, Championship specification marked for the championship. Complete front axle.
CSFFCIC5	Racesport	Braided Brake Lines	Braking	Set of Racesport Stainless steel Teflon Braided Brake lines PVC encased.
<b>For the avoidance of any doubt: All of the above parts are supplied by Racesport as a full build kit package. Spares and replacement parts must only be purchased through Racesport Ltd.</b>				
<b>Tyres</b>				
Tyres must only be supplied by Mr Tyre Motorsport. Email: <a href="mailto:sales@mrtyremotorsport.com">sales@mrtyremotorsport.com</a> Tel: 01827 211021				
Tyres	Dunlop	Race Tyres	Tyres	Dunlop - 195/50R15 D203G (Dry) Dunlop - 185/58R15 GY (Wet)
				Wet - Dunlop 637703 - 180/58R15 GY WET-L-TC02W3 or 640958 180/58R15 GY WET-L-TC03W3
				Wet - Dunlop 637704 - 180/58R15 GY WET-R-TC02W3 or 640959 180/58R15 GY WET-L-TC03W3
Tyres must only be supplied by Mr Tyre Motorsport. Email: <a href="mailto:sales@mrtyremotorsport.com">sales@mrtyremotorsport.com</a> Tel: 01827 211021				



A socially-minded standard of behaviour is expected from everyone within the motorsport community.

By participating in a Motorsport UK event in any capacity you agree to follow the values of the Respect Code:

Motorsportuk.org/racewithrespect  
#RaceWithRespect

### **The Values**

- Respect
- Integrity
- Self-Control
- Fair play
- Good Manners

I pledge to #RaceWithRespect and:

- Contribute to a welcoming and friendly environment that ensures the safety and welfare of all participants.
- Always behave with integrity and uphold fairness in the sport; play my part in keeping the sport safety through your actions
- Treat everyone with respect, regardless of their gender, ethnic or social background, language, religious or other beliefs, disability, sexual identity or other status
- Recognise that we all represent the sport and therefore have a duty to be polite and respectful to all staff, officials, fellow competitors, volunteers, as well as fans and supporters
- Respect the rules, regulations and authority of the officials and Motorsport UK

Any breach of these obligations may result in disciplinary action.

## Professional Standards in Motorsport Coaching



### JUNIOR RACING CHAMPIONSHIPS – COACHING BEST PRACTICE

It is important that we all contribute to a positive environment for our young drivers. To further enhance the expectations for all detailed below are best practices and provides a support for the Driver Coaches as well as the Championship Organisers, Parents and Teams.

#### Maximising the Driver Experience

Create a positive experience by building strong relationships with drivers through excellent communication, technical expertise, and responsiveness. Advocate for motorsport growth and driver retention via structured, engaging programmes of work.

##### Do's:

- Build rapport and trust early.
- Communicate clearly and listen actively.
- Design programs that engage and inspire.
- Champion motorsport participation.

##### Don'ts:

- Ignore driver feedback or concerns.
- Deliver generic, unstructured sessions.
- Focus solely on performance without fostering enjoyment.

#### Promoting Welfare and Providing a Safe, Inclusive Coaching Environment

Prioritise driver welfare and foster a supportive atmosphere. Manage behaviour positively while delivering safe and inclusive practices.

##### Do's:

- Regularly assess and address welfare needs.
- Create a respectful, inclusive environment.
- Deliver well-structured, safe activities.
- Promote reporting routes and empower individuals to share any concerns or worries they have.

##### Don'ts:

- Tolerate discriminatory or unsafe behaviour.
- Neglect individual needs.
- Ignore signs of stress or discomfort.

#### Understanding Your Role as a Coach

Stay within professional boundaries, manage stakeholder relationships, and articulate a clear coaching philosophy to positively impact drivers on and off the track.

##### Do's:

- Use critical thinking and initiative.
- Foster collaborative relationships with parents and stakeholders.
- Develop a philosophy centered on holistic driver development.

##### Don'ts:

- Overstep boundaries or micromanage.
- Dismiss the input of parents or stakeholders.
- Lack a clear vision or philosophy.

## Professional Standards in Motorsport Coaching



### Maintaining Professional Practice

Deliver driver-focused coaching with high standards in relationship management, duty of care, and professional development while adhering to data protection laws.

#### Do's:

- Prioritise driver safety and performance, identify and mitigate risks as part of your pre-activity planning.
- Handle data responsibly.
- Pursue ongoing professional development.

#### Don'ts:

- Compromise on duty of care or safety.
- Ignore regulations on data handling.
- Remain stagnant in your learning and development.

### Planning, Delivering, and Reviewing Coaching Sessions

Plan, deliver, and review inclusive, effective sessions tailored to participants' needs. Evaluate and adapt to ensure engagement, variety, and progression.

#### Do's:

- Plan with drivers' goals in mind.
- Use varied and progressive methods.
- Adapt based on real-time feedback.

#### Don'ts:

- Stick rigidly to ineffective plans.
- Deliver monotonous or one-size-fits-all sessions.
- Avoid post-session evaluations.

### Planning, Delivering, and Reviewing Coaching Programmes

Design inclusive programmes of work aligned with drivers' long-term goals. Continuously evaluate effectiveness and adapt to maintain engagement and progression.

#### Do's:

- Tailor programs to individual aspirations.
- Foster enthusiasm for ongoing learning.
- Evaluate and refine regularly.

#### Don'ts:

- Use a generic, repetitive programme structure.
- Overlook long-term development.
- Fail to engage drivers in planning.

### Motorsport Legislation, Organisational Policies, and Procedures

Adhere to all legislation, policies, and procedures, ensuring professional integrity and alignment with Motorsport UK's standards.

#### Do's:

- Stay updated on policies and legislation.
- Promote Race with Respect.
- Meet and maintain professional standards.

#### Don'ts:

- Disregard legal and regulatory compliance requirements.
- Overlook the importance of respect and integrity in coaching.
- Neglect ongoing professional accountability.